

ARENDELL AVE

SITE PLAN SET

1ST SUBMITTAL TO TOWN OF ZEBULON: 06/01/2021

SITE INFORMATION:	
LOCATION:	706 N ARENDELL AVE, ZEBULON
COUNTY:	WAKE
PARENT PIN:	2705274220 & 2705275069 & 2705275233
DB/PG:	012055/ 00567
ZONING:	DTP
ACREAGE:	1.38 ACRES
CURRENT LAND USE MAP CLASSIFICATION:	TN
PROPOSED LAND USE MAP CLASSIFICATION:	TN
LAND CLASS:	RESIDENTIAL
MINIMUM BUILDING SETBACKS:	
FRONT YARD:	0' (40' MAX)
SIDE YARD:	0' OR 5'
REAR YARD:	15'
CORNER YARD:	0'
GARAGE:	0'
RIGHT OF WAY & OTHER AREAS:	
RIGHT OF WAY DEDICATION:	0.00 AC
NATURAL WETLANDS:	0.00 AC
STREAM BUFFER:	0.00 AC
LOT ACREAGE:	
TOTAL NUMBER PROPOSED LOTS:	12
MAXIMUM ALLOWED DENSITY:	10 DU/AC
PROPOSED DENSITY:	8.70 DU/AC
MINIMUM ALLOWED LOT SIZE:	3,000 SF
MINIMUM PROPOSED LOT SIZE:	3,005 SF
MAXIMUM PROPOSED LOT SIZE:	3,200 SF
AVERAGE PROPOSED LOT SIZE:	3,000 SF
MINIMUM ALLOWABLE LOT WIDTH:	30'
MINIMUM PROPOSED LOT WIDTH:	30'
MAXIMUM LOT COVERAGE:	85% OF LOT
OPEN SPACE BREAKDOWN:	
PROPERTY BOUNDARY:	60,200 SF (1.38 AC)
REQUIRED URBAN SET-ASIDE:	6020 SF (10% OF TOTAL SITE)
PROVIDED URBAN SET-ASIDE:	14,361 SF (0.33 AC)
IMPERVIOUS AREAS:	
ROADWAYS / PARKING:	6,139 SF (0.14 AC)
SIDEWALKS:	0.03 AC
LOTS (3,000 SF/LOT):	36,000 SF (0.83 AC)
TOTAL ON-SITE IMPERVIOUS AREA:	25,813 SF (0.59 AC)
TOTAL ON-SITE IMPERVIOUS PERCENT:	42.8%
UTILITY DEMANDS:	
SEWAGE USAGE:	4,320 GDP
	3 BED X 120 GPD/BED X 12 UNITS
WATER USAGE:	4,320 GDP
	3 BED X 120 GPD/BED X 12 UNITS
DISTURBED AREA:	
TOTAL DISTURBED AREA:	44,108 (1.00 AC)
STREET TYPE SUMMARY:	
16' ROW SECTION:	353 LF

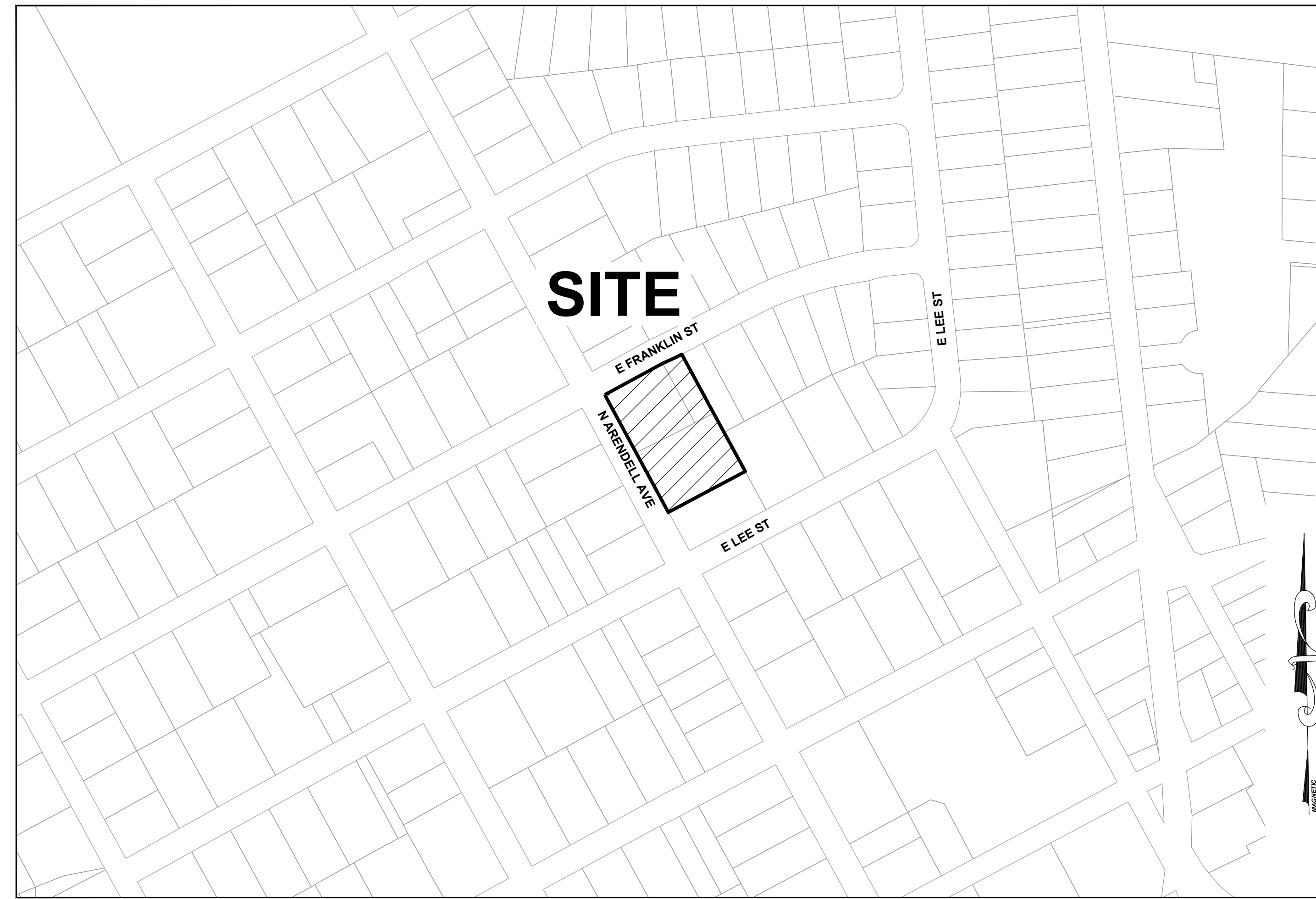

VICINITY MAP

1" = 200'

SHEET INDEX	
C-0.0	COVER SHEET
C-1.0	EXISTING CONDITIONS PLAN
C-2.0	SITE PLAN
C-3.0	UTILITY PLAN
C-4.0	GRADING PLAN
C-5.0	STORMWATER PLAN
C-6.0	EROSION CONTROL PLAN
C-7.0	LANDSCAPING PLAN
D-1.0	WATER DETAILS

PERMIT INFORMATION:	
(PERMITTING AUTHORITY, PERMIT IDENTIFIERS, & EFFECTIVE DATES)	
TOWN OF ZEBULON PLANNING AND ZONING:	
- EFFECTIVE DATE OF ZONING APPROVAL:	XX-XX-2020
- EFFECTIVE DATE OF MASTER PLAN APPROVAL:	XX-XX-2020
WAKE COUNTY ENVIRONMENTAL:	
-LAND DISTURBANCE PERMIT:	SEC-XXXXXX-XXXX
-STORMWATER PERMIT:	SWF-XXXXXX-XXXX
NCDWR/CITY OF ZEBULON PUBLIC UTILITIES:	
-WATER EXTENSION PERMIT:	W-XXXX
-SEWER EXTENSION PERMIT:	S-XXXX
NC DEPT. OF TRANSPORTATION:	
-DRIVEWAY PERMIT:	D51-XXX-XXXX (DATE: XX-XX-XXXX)
-2 PARTY ENCROACHMENT AGMT:	E51-XXX-XXXX (DATE: XX-XX-XXXX)
-3 PARTY ENCROACHMENT AGMT:	E51-XXX-XXXX (DATE: XX-XX-XXXX)
U.S. ARMY CORPS OF ENGINEERS:	
-IMPACT PERMIT:	NOT REQUIRED
NC DIVISION OF WATER QUALITY:	
-BUFFER IMPACT AUTHORIZATION:	NOT REQUIRED

SURVEYOR:	
TAYLOR LAND CONSULTANTS 5448 APEX PEAKWAY APEX, NC 27502 919-801-1104 (O) 919-337-7998 (M) CONTACT: JEREMY TAYLOR, PLS jeremy@taylorlc.com	
CIVIL ENGINEERING:	
STRONG ROCK ENGINEERING GROUP, PLLC PO BOX 55992 RALEIGH, NC 27624 COMPANY LICENSE # P-2166 CONTACT: RHONDA BREWINGTON, PE 910-527-9209 (P) rhonda@strongrockgroup.com	

PRELIMINARY CONSTRUCTION DRAWINGS: THESE DRAWINGS SHALL NOT BE USED FOR CONSTRUCTION UNTIL APPROVED BY ALL AUTHORITIES HAVING JURISDICTION AND RELEASED BY THE ENGINEER OF RECORD.

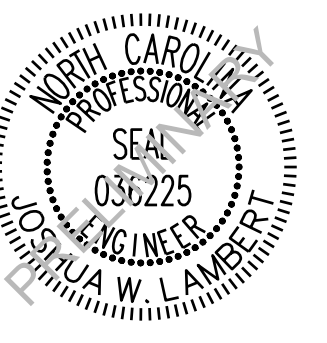

STRONGROCK
ENGINEERING GROUP
STRONG ROCK ENGINEERING GROUP, PLLC | COMPANY LICENSE # P-2166
8362 SIX FORKS RD., SUITE 104 RALEIGH, NC 27615 | JOSH@STRONGROCKENGINEERING.COM

STRONG ROCK PROJECT	NOT FOR CONSTRUCTION	SCALE AS SHOWN	DESIGNED BY	RLB	SRG	JWL

TRUE- ZEBULON-ARENDELL
TOWN OF ZEBULON, WAKE COUNTY, NORTH CAROLINA
CONSTRUCTION PLANS
COVER SHEET

DRAWING SHEET
C-0.0
01 OF 09

No.	REVISIONS	DATE	BY

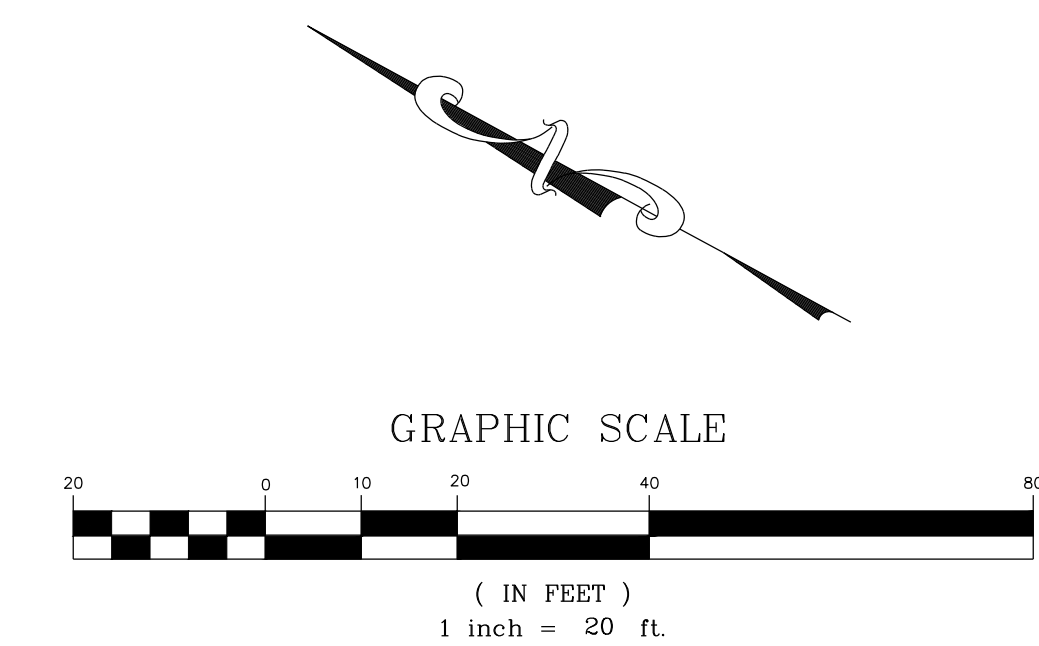
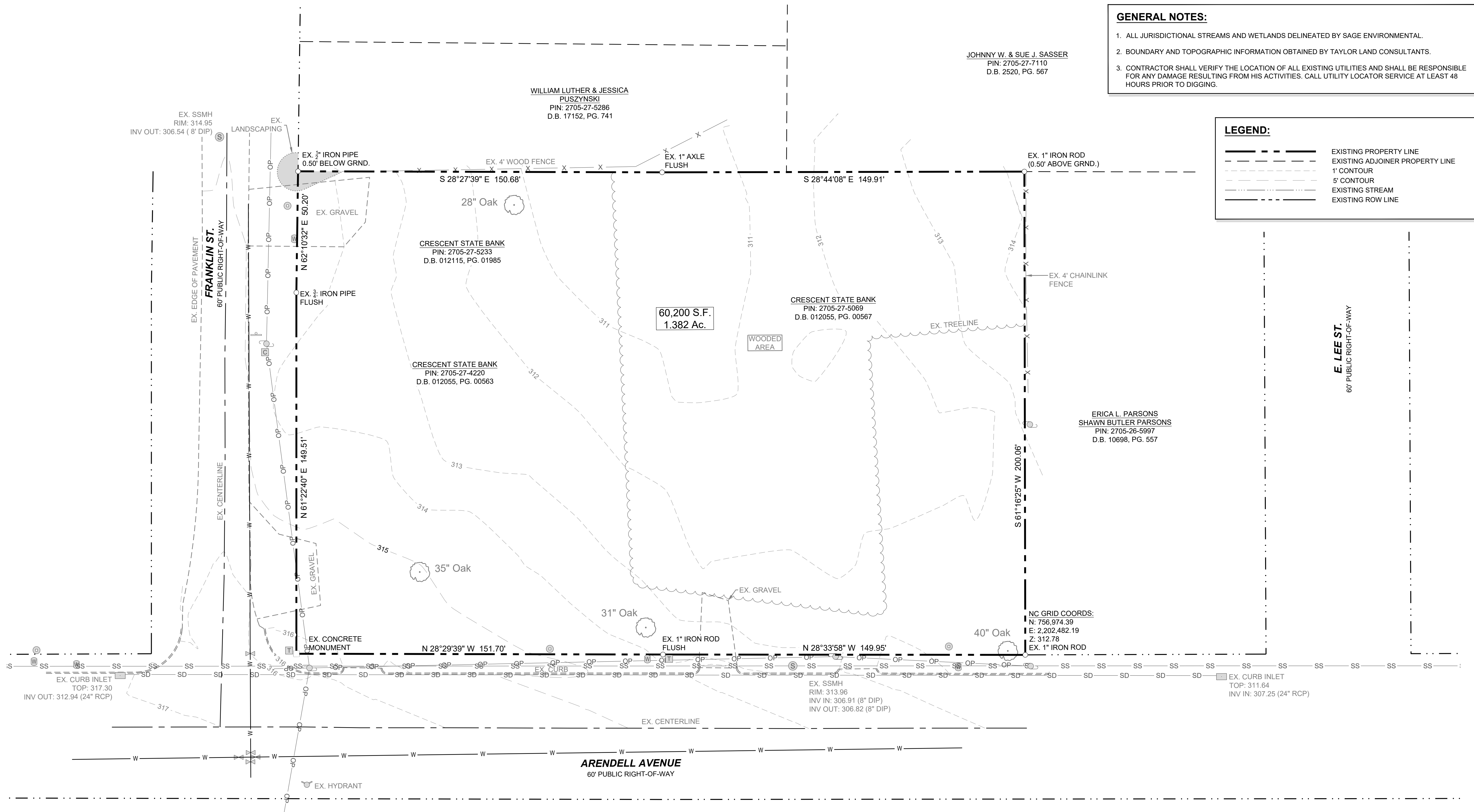

PRELIMINARY CONSTRUCTION DRAWINGS; THESE DRAWINGS SHALL NOT BE USED FOR CONSTRUCTION UNTIL APPROVED BY ALL AUTHORITIES HAVING JURISDICTION AND RELEASED BY THE ENGINEER OF RECORD.

NO.	REVISIONS	DATE	BY

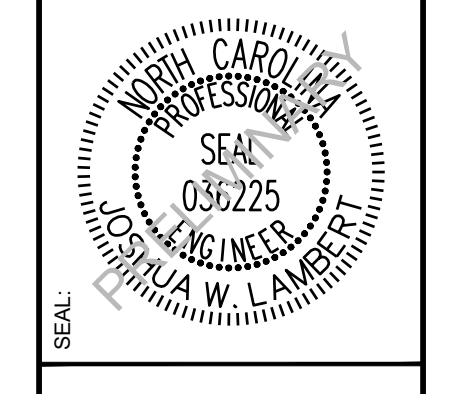

STRONGROCK
ENGINEERING GROUP

STRONG ROCK ENGINEERING GROUP, PLLC | COMPANY LICENSE # P-2166
8362 SIX FORKS RD., SUITE 104 RALEIGH, NC 27615 | JOSH@STRONGROCKENGINEERING.COM

STRONG ROCK PROJECT	NOT FOR CONSTRUCTION	SCALE AS SHOWN	DESIGNED BY	RLB	SRG	DRAWN BY	CHECKED BY	JWL

TRUE- ZEBULON-AREDELLE
TOWN OF ZEBULON, WAKE COUNTY, NORTH CAROLINA
CONSTRUCTION PLANS
EXISTING CONDITIONS PLAN

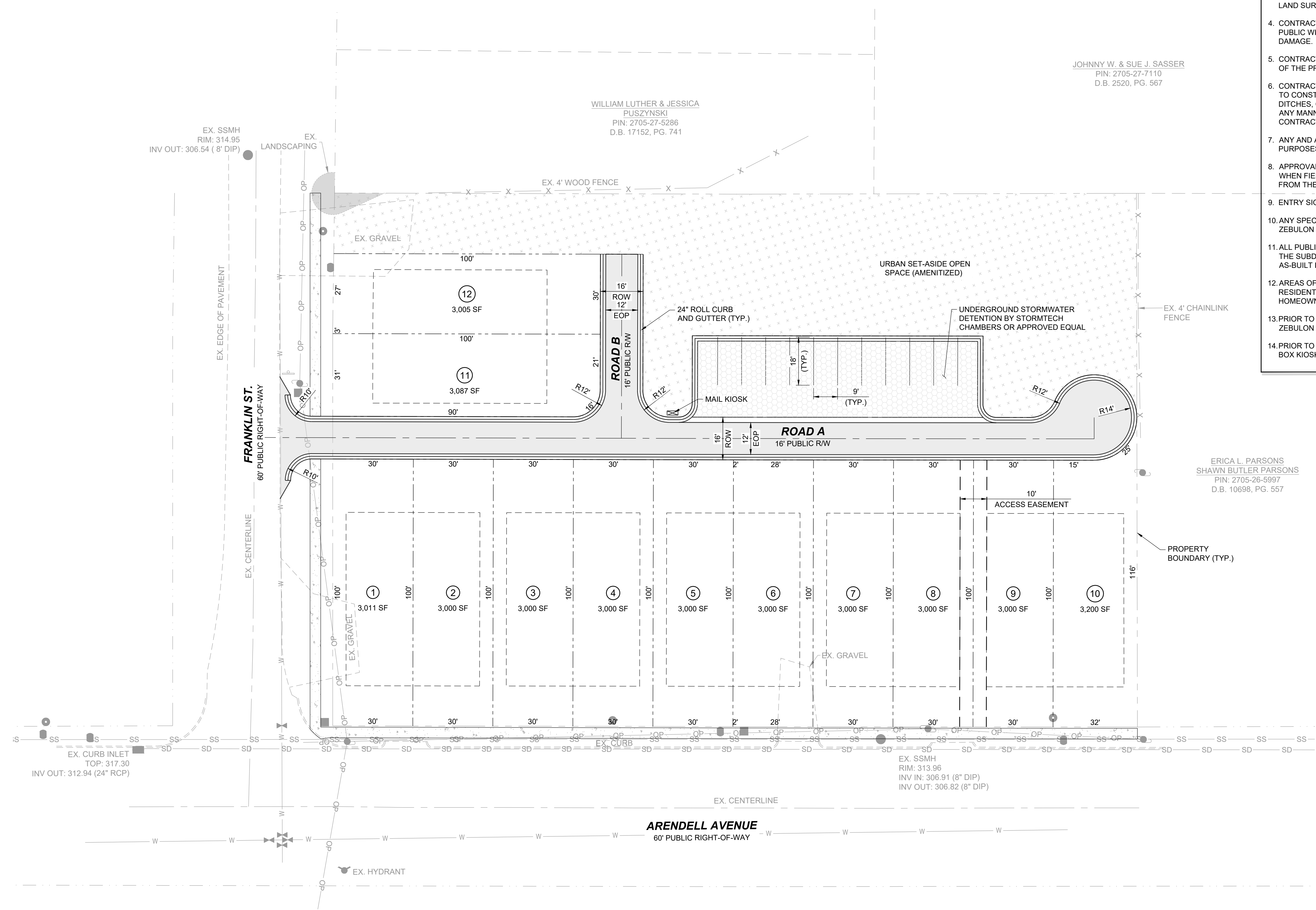

JOHNNY W. & SUE J. SASSER
 PIN: 2705-27-7110
 D.B. 2520, PG. 567

WILLIAM LUTHER & JESSICA
 PUSZYNSKI
 PIN: 2705-27-5286
 D.B. 17152, PG. 741

ERICA L. PARSONS
 SHAWN BUTLER PARSONS
 PIN: 2705-26-5997
 D.B. 10698, PG. 557

- GENERAL NOTES:**
1. ALL CONSTRUCTION SHALL BE PER TOWN OF ZEBULON STANDARDS AND SPECIFICATIONS.
 2. CONTRACTOR SHALL CONTACT ALL OWNERS OF EASEMENTS, RIGHT-OF-WAYS AND UTILITIES, PUBLIC OR PRIVATE BEFORE WORKING IN THESE AREAS.
 3. PROTECT ALL PROPERTY MONUMENTS AND PINS. MONUMENTS AND PINS THAT WILL BE DISTURBED DURING CONSTRUCTION SHALL BE REFERENCED AND REPLACED BY A LICENSED LAND SURVEYOR AT THE COST OF THE CONTRACTOR.
 4. CONTRACTOR SHALL MAINTAIN THE SITE IN SUCH A MANNER THAT WORKMEN AND THE PUBLIC WILL BE PROTECTED FROM INJURY AND ADJOINING PROPERTY PROTECTED FROM DAMAGE.
 5. CONTRACTOR SHALL REMOVE ALL TRASH AND DEBRIS FROM THE SITE UPON COMPLETION OF THE PROJECT AND AT LEAST ONCE A WEEK DURING CONSTRUCTION.
 6. CONTRACTOR IS RESPONSIBLE FOR DAMAGE TO ANY EXISTING ITEM AID/OR MATERIAL DUE TO CONSTRUCTION OPERATIONS. ALL STREET SURFACES, UTILITY POLES, CULVERTS, DITCHES, CURB AND GUTTER OR OTHER STRUCTURES THAT ME DISTURBED OR DAMAGED IN ANY MANNER AS A RESULT OF CONSTRUCTION SHALL BE REPLACED OR REPAIRED BY THE CONTRACTOR IN ACCORDANCE WITH THE APPROPRIATE SPECIFICATIONS.
 7. ANY AND ALL QUANTITIES SHOWN OR IMPLIED ON THE PLANS ARE FOR ESTIMATION PURPOSES ONLY.
 8. APPROVAL OF THIS PLAN IS NOT AN AUTHORIZATION TO GRADE ADJACENT PROPERTIES. WHEN FIELD CONDITIONS WARRANT OFFSITE GRADING, PERMISSION MUST BE OBTAINED FROM THE AFFECTED PROPERTY OWNERS.
 9. ENTRY SIGNS SHALL BE LOCATED IN A DEDICATED EASEMENT.
 10. ANY SPECIALITY STREET SIGNS INCLUDING POSTS SHALL BE SUBMITTED TO THE TOWN OF ZEBULON FOR REVIEW AND APPROVAL PRIOR TO INSTALLATION.
 11. ALL PUBLIC AND PRIVATE EASEMENTS SHALL BE RECORDED AS PART OF THE FINAL PLAT OF THE SUBDIVISION. EASEMENTS BASED OF CENTER OF UTILITY OR PIPE SHALL BE PER AS-BUILT LOCATIONS.
 12. AREAS OF PARENT PARCEL THAT ARE NOT SUBDIVIDED TO CREATE SINGLE FAMILY RESIDENTIAL LOTS ARE TO REMAIN AS ONE PARCEL TO BE OWNED AND MAINTAINED BY THE HOMEOWNERS ASSOCIATION OF THE NEIGHBORHOOD.
 13. PRIOR TO FINAL PLAT, DEVELOPER SHALL SUBMIT A LIGHTING PLAN TO THE TOWN OF ZEBULON SHOWING LIGHT FIXTURE DETAILS AND PHOTOMETRICS.
 14. PRIOR TO FINAL PLAT, DEVELOPER SHALL SUBMIT CUT SHEETS FOR PARK BENCHES, MAIL BOX KIOSK, AND PEDESTRIAN WAYFINDING.

LEGEND:

	EXISTING PROPERTY LINE
	ROADWAY CENTER LINE
	PROPOSED PROPERTY LINE
	STANDARD CURB & GUTTER
	ASPHALT PAVEMENT
	OPEN SPACE

NO.	REVISIONS	DATE	BY

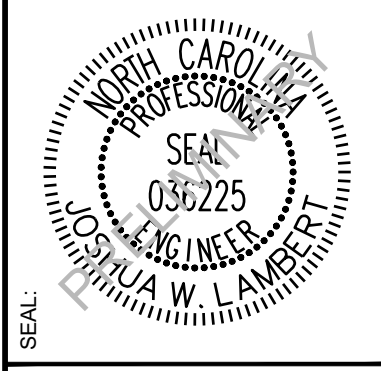

STRONGROCK
 ENGINEERING GROUP
 STRONG ROCK ENGINEERING GROUP, PLLC | COMPANY LICENSE # P-2166
 8362 SIX FORKS RD., SUITE 104 RALEIGH, NC 27615 | JOSH@STRONGROCKENGINEERING.COM

STRONG ROCK PROJECT	NOT FOR CONSTRUCTION	SCALE AS SHOWN	DESIGNED BY	DRAWN BY	CHECKED BY

TRUE- ZEBULON-ARENDELL
 TOWN OF ZEBULON, WAKE COUNTY, NORTH CAROLINA
 CONSTRUCTION PLANS
SITE PLAN

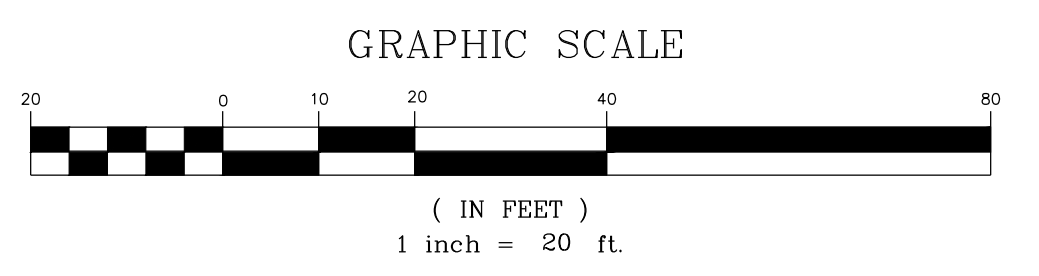

PRELIMINARY CONSTRUCTION DRAWINGS; THESE DRAWINGS SHALL NOT BE USED FOR CONSTRUCTION UNTIL APPROVED BY ALL AUTHORITIES HAVING JURISDICTION AND RELEASED BY THE ENGINEER OF RECORD.

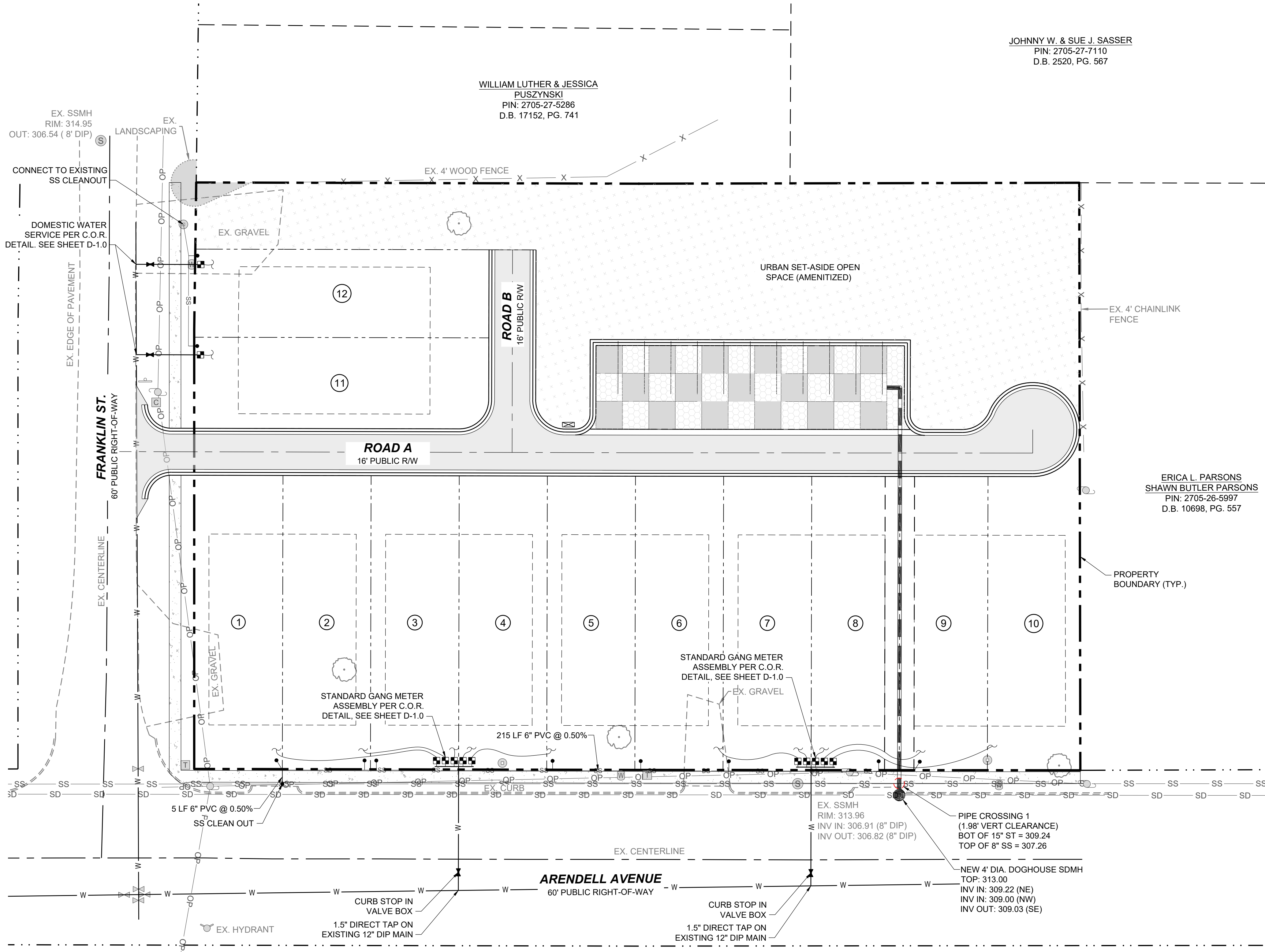

JOHNNY W. & SUE J. SASSER
 PIN: 2705-27-7110
 D.B. 2520, PG. 567

WILLIAM LUTHER & JESSICA
 PUSZYSKI
 PIN: 2705-27-5286
 D.B. 17152, PG. 741

ERICA L. PARSONS
 SHAWN BUTLER PARSONS
 PIN: 2705-26-5997
 D.B. 10698, PG. 557

UTILITY NOTES:

- ALL MATERIALS & CONSTRUCTION METHODS SHALL BE IN ACCORDANCE WITH CITY OF ZEBULON DESIGN STANDARDS, DETAILS & SPECIFICATIONS (REFERENCE: CORPUD HANDBOOK, CURRENT EDITION)
- UTILITY SEPARATION REQUIREMENTS (TAKEN FROM CORPUD HANDBOOK, 2014 EDITION, SEWER DESIGN, MATERIAL, & CONSTRUCTION STANDARDS, SECTION 1. a. 15.):
 - A DISTANCE OF 100' SHALL BE MAINTAINED BETWEEN SANITARY SEWER & ANY PRIVATE OR PUBLIC WATER SUPPLY SOURCE SUCH AS AN IMPOUNDED RESERVOIR USED AS A SOURCE OF DRINKING WATER. IF ADEQUATE LATERAL SEPARATION CANNOT BE ACHIEVED, FERROUS SANITARY SEWER PIPE SHALL BE SPECIFIED & INSTALLED TO WATERLINE SPECIFICATIONS. HOWEVER, THE MINIMUM SEPARATION SHALL NOT BE LESS THAN 25' FROM A PRIVATE WELL OR 50' FROM A PUBLIC WELL.
 - WHEN INSTALLING WATER &/OR SEWER MAINS, THE HORIZONTAL SEPARATION BETWEEN UTILITIES SHALL BE 10'. IF THIS SEPARATION CANNOT BE MAINTAINED DUE TO EXISTING CONDITIONS, THE VARIATION ALLOWED IS THE WATER MAIN IN A SEPARATE TRENCH WITH THE ELEVATION OF THE WATER MAIN AT LEAST 18" ABOVE THE TOP OF THE SEWER & MUST BE APPROVED BY THE PUBLIC UTILITIES DIRECTOR. ALL DISTANCES ARE MEASURED FROM OUTSIDE DIAMETER TO OUTSIDE DIAMETER.
 - WHERE IT IS IMPOSSIBLE TO OBTAIN PROPER SEPARATION, OR ANYTIME A SANITARY SEWER PASSES OVER A WATERMAIN, DIP MATERIALS OR STEEL ENCASUREMENT EXTENDED 10' ON EACH SIDE OF CROSSING MUST BE SPECIFIED & INSTALLED TO WATERLINE SPECIFICATIONS.
 - 5.0' MINIMUM HORIZONTAL SEPARATION IS REQUIRED BETWEEN ALL SANITARY SEWER & STORM SEWER FACILITIES, UNLESS DIP MATERIAL IS SPECIFIED FOR SANITARY SEWER.
 - MAINTAIN 18" MIN. VERTICAL SEPARATION AT ALL WATERMAIN & RCP STORM DRAIN CROSSINGS; MAINTAIN 24" MIN. VERTICAL SEPARATION AT ALL SANITARY SEWER & RCP STORM DRAIN CROSSINGS. WHERE ADEQUATE SEPARATIONS CANNOT BE ACHIEVED, SPECIFY DIP MATERIALS & A CONCRETE CRADLE HAVING 6" MIN. CLEARANCE (PER CORPUD DETAILS W-41 & S-49).
 - ALL OTHER UNDERGROUND UTILITIES SHALL CROSS WATER & SEWER FACILITIES WITH 18" MIN. VERTICAL SEPARATION REQUIRED.
- ANY NECESSARY FIELD REVISIONS ARE SUBJECT TO REVIEW & APPROVAL OF AN AMENDED PLAN &/OR PROFILE BY THE CITY OF ZEBULON PUBLIC UTILITIES DEPARTMENT PRIOR TO CONSTRUCTION.
- CONTRACTOR SHALL MAINTAIN CONTINUOUS WATER & SEWER SERVICE TO EXISTING RESIDENCES & BUSINESSES THROUGHOUT CONSTRUCTION OF PROJECT. ANY NECESSARY SERVICE INTERRUPTIONS SHALL BE PRECEDED BY A 24 HOUR ADVANCE NOTICE TO THE CITY OF ZEBULON PUBLIC UTILITIES DEPARTMENT.
- 3.0' MINIMUM COVER IS REQUIRED ON ALL WATER MAINS & SEWER FORCEMAINS. 4.0' MINIMUM COVER IS REQUIRED ON ALL REUSE MAINS.
- IT IS THE DEVELOPER'S RESPONSIBILITY TO ABANDON OR REMOVE EXISTING WATER & SEWER SERVICES NOT BEING USED IN REDEVELOPMENT OF A SITE UNLESS OTHERWISE DIRECTED BY THE CITY OF ZEBULON PUBLIC UTILITIES DEPARTMENT. THIS INCLUDES ABANDONING TAP AT MAIN & REMOVAL OF SERVICE FROM ROW OR EASEMENT PER CORPUD HANDBOOK PROCEDURE.
- INSTALL 3/4" COPPER WATER SERVICES WITH METERS LOCATED AT ROW OR WITHIN A 2'X2' WATERLINE EASEMENT IMMEDIATELY ADJACENT NOTE: IT IS THE APPLICANT'S RESPONSIBILITY TO PROPERLY SIZE THE WATER SERVICE FOR EACH CONNECTION TO PROVIDE ADEQUATE FLOW & PRESSURE.
- INSTALL 4" PVC SEWER SERVICES @ 1.0% MINIMUM GRADE WITH CLEANOUTS LOCATED AT ROW OR EASEMENT LINE & SPACED EVERY 75 LINEAR FEET MAXIMUM.
- PRESSURE REDUCING VALVES ARE REQUIRED ON ALL WATER SERVICES EXCEEDING 80 PSI. BACKWATER VALVES ARE REQUIRED ON ALL SANITARY SEWER SERVICES HAVING BUILDING DRAINS LOWER THAN 1.0' ABOVE THE NEXT UPSTREAM MANHOLE.
- A 3-PARTY ENCROACHMENT AGREEMENT BETWEEN THE NCDOT, THE CITY OF ZEBULON PUBLIC UTILITIES, AND THE DEVELOPER MAY BE NEEDED FOR WATER AND SEWER SERVICE TAPS WITHIN THE NCDOT MAINTAINED RIGHT OF WAY. CROSS-CONNECTION CONTROL PROTECTION DEVICES ARE REQUIRED BASED ON DEGREE OF HEALTH HAZARD INVOLVED AS LISTED IN APPENDIX-B OF THE RULES GOVERNING PUBLIC WATER SYSTEMS IN NORTH CAROLINA. THESE GUIDELINES ARE THE MINIMUM REQUIREMENTS. THE DEVICES SHALL MEET AMERICAN SOCIETY OF SANITARY ENGINEERING (ASSE) STANDARDS OR BE ON THE UNIVERSITY OF SOUTHERN CALIFORNIA APPROVAL LIST. THE DEVICES SHALL BE INSTALLED AND TESTED (BOTH INITIAL AND PERIODIC TESTING THEREAFTER) IN ACCORDANCE WITH THE MANUFACTURER'S RECOMMENDATIONS OR THE LOCAL CROSS-CONNECTION CONTROL PROGRAM, WHICHEVER IS MORE STRINGENT. CONTACT JOANIE HARTLEY AT (919) 996-5923 OR JOANIE.HARTLEY@RALEIGHNC.GOV FOR MORE INFORMATION.
- PROPOSED PRIVATE UTILITIES (POWER, TELEPHONE, NATURAL GAS, CABLE TV) ARE NOT SHOWN ON THIS PLAN. THE DEVELOPER SHALL COORDINATE THE INSTALLATION OF THOSE UTILITIES WHEN INSTALLING PUBLIC UTILITIES.
- CONTRACTOR SHALL LOCATE ALL UNDERGROUND UTILITIES PRIOR TO ANY LAND DISTURBANCE ACTIVITIES. IF ANY EXISTING UTILITIES ARE LOCATED THAT CAUSE A CONFLICT WITH PROPOSED UTILITIES, CONTRACTOR SHALL IMMEDIATELY NOTIFY THE CIVIL ENGINEER OF RECORD IN WRITING. IF SUCH A SCENARIO ARISES, THE PROPOSED UTILITY IN QUESTION SHALL NOT BE INSTALLED UNTIL AN ACCEPTABLE SOLUTION IS PREPARED AND APPROVED BY THE AUTHORITY HAVING JURISDICTION.
- CONTRACTOR SHALL ADJUST ALL CLEANOUTS, VALVE BOXES, MANHOLES, ETC. TO THE FINISHED GRADES ESTABLISHED BY THE PROJECT.
- ALL UNDERGROUND ELECTRICAL CONDUITS SHALL HAVE A MINIMUM COVER OF 36"; GAS AND COMMUNICATION LINES SHALL HAVE DEPTH AND SPACING AS SPECIFIED BY SERVICE COMPANY.
- MAXIMUM SPACING FOR SANITARY SEWER CLEANOUTS IS 75 FEET. ALL CLEANOUTS LOCATED IN DRIVE AISLES AND/OR PARKING AREAS SHALL TO BE TRAFFIC RATED.
- INVERT AT CLEANOUT IS INVERT ELEVATION AT THE CONNECTION OF THE HORIZONTAL BEND.
- A 3-FOOT CLEAR SPACE SHALL BE MAINTAINED AROUND THE CIRCUMFERENCE OF FIRE HYDRANTS.
- CONTRACTOR SHALL PROVIDE PROPER NOTIFICATION TO AUTHORITIES HAVING JURISDICTION AS SPECIFIED IN AGENCY PERMIT CONDITIONS. AS A COURTESY, CIVIL ENGINEER OF RECORD REQUESTS NOTIFICATION.
- THRUST RESTRAINT SHALL BE IN ACCORDANCE WITH CITY OF ZEBULON STANDARD SPECIFICATIONS.
- WATER LINE TESTING AND STERILIZATION SHALL BE IN ACCORDANCE WITH CITY OF ZEBULON STANDARD SPECIFICATIONS.
- ALL NEW MANHOLES SHALL BE ECCENTRIC UNLESS OTHERWISE NOTED.
- ALL WATER AND SEWER SERVICE CONNECTIONS SHALL BE INSTALLED BY A LICENSED PLUMBER.

NO.	REVISIONS	DATE	BY

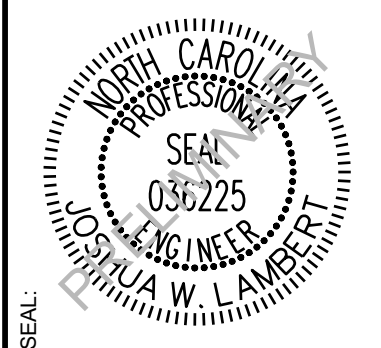

STRONGROCK
 ENGINEERING GROUP
 STRONG ROCK ENGINEERING GROUP, PLLC | COMPANY LICENSE # P-2166
 8362 SIX FORKS RD., SUITE 104 RALEIGH, NC 27615 | JOSH@STRONGROCKENGINEERING.COM

STRONG ROCK PROJECT	NOT FOR CONSTRUCTION	SCALE AS SHOWN	DESIGNED BY	DRWN BY	SRG	CHKD BY	JWL
---------------------	----------------------	----------------	-------------	---------	-----	---------	-----

SITE PERMITTING APPROVAL:
WATER AND SEWER PERMITS (IF APPLICABLE)

THE CITY OF ZEBULON CONSENTS TO THE CONNECTION AND EXTENSION OF THE CITY'S PUBLIC SEWER SYSTEM AS SHOWN ON THIS PLAN. THE MATERIAL AND CONSTRUCTION METHODS USED FOR THIS PROJECT SHALL CONFORM TO THE STANDARDS AND SPECIFICATIONS OF THE CITY'S PUBLIC UTILITIES HANDBOOK.

CITY OF ZEBULON PUBLIC UTILITIES DEPARTMENT PERMIT # _____

THE CITY OF ZEBULON CONSENTS TO THE CONNECTION AND EXTENSION OF THE CITY'S PUBLIC WATER SYSTEM AS SHOWN ON THIS PLAN. THE MATERIAL AND CONSTRUCTION METHODS USED FOR THIS PROJECT SHALL CONFORM TO THE STANDARDS AND SPECIFICATIONS OF THE CITY'S PUBLIC UTILITIES HANDBOOK.

CITY OF ZEBULON PUBLIC UTILITIES DEPARTMENT PERMIT # _____

THE CITY OF ZEBULON CONSENTS TO THE CONNECTION TO ITS PUBLIC SEWER SYSTEM AND EXTENSION OF THE PRIVATE SEWER COLLECTION SYSTEM AS SHOWN ON THIS PLAN. THE MATERIAL AND CONSTRUCTIONS METHODS USED FOR THIS PROJECT SHALL CONFORM TO THE STANDARDS AND SPECIFICATIONS OF THE CITY'S PUBLIC UTILITIES HANDBOOK.

CITY OF ZEBULON PUBLIC UTILITIES DEPARTMENT PERMIT # _____

NOTE:
 WHERE PROPOSED SS PASSES OVER WATER AND STORM, SS MUST BE DUCTILE IRON WITH CONCRETE COLLAR, REFER TO DETAIL S-49.

CITY OF ZEBULON - PLANS AUTHORIZED FOR CONSTRUCTION:

ELECTRONIC APPROVAL: THIS APPROVAL IS BEING ISSUED ELECTRONICALLY. THIS APPROVAL IS VALID ONLY UPON THE SIGNATURE OF A CITY OF ZEBULON REVIEW OFFICER BELOW. THE CITY WILL RETAIN A COPY OF THE APPROVED PLANS. ANY WORK AUTHORIZED BY THIS APPROVAL MUST PROCEED IN ACCORDANCE WITH THE PLANS KEPT ON FILE WITH THE CITY. THIS ELECTRONIC APPROVAL MAY NOT BE EDITED ONCE ISSUED. ANY MODIFICATION TO THIS APPROVAL ONCE ISSUED WILL INVALIDATE THIS APPROVAL.

CITY OF ZEBULON DEVELOPMENT APPROVAL _____

ZEBULON WATER REVIEW OFFICER _____

LEGEND:

	MASTER PLAN BOUNDARY
	ADJOINER PROPERTY LINE
	EXISTING WATERLINE
	EXISTING SANITARY SEWER
	PROPOSED WATERLINE
	PROPOSED SANITARY SEWER
	PROPOSED LOT LINE
	PROPOSED ROLL CURB AND GUTTER
	EXISTING FIRE HYDRANT
	EXISTING WATER VALVE
	EXISTING UTILITY POLE
	EXISTING TELEPHONE PEDEST
	PROPOSED GATE VALVE (GV)
	PROPOSED TEE
	PROPOSED CLEANOUT

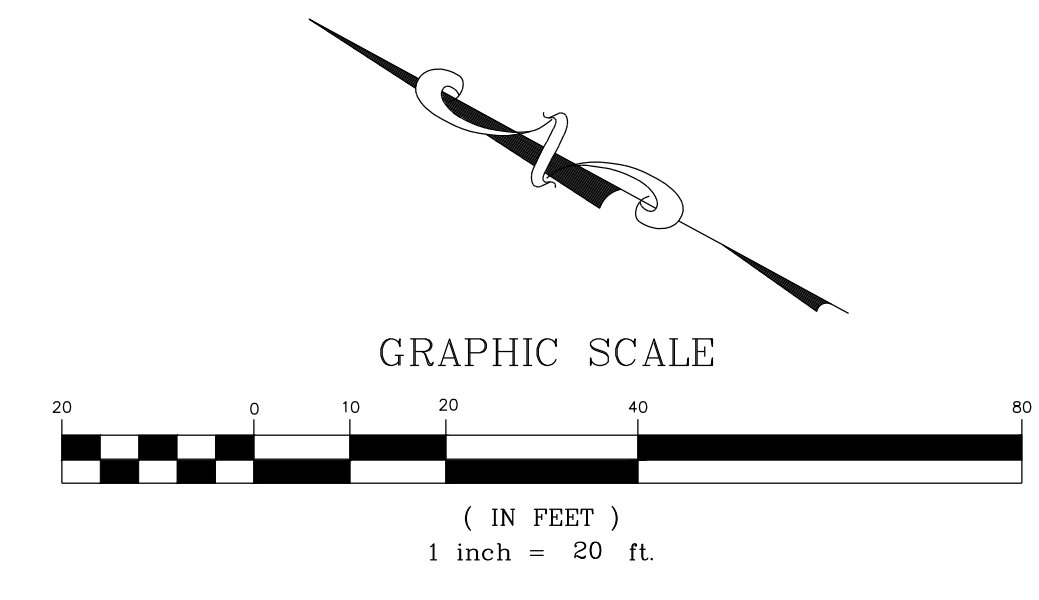

PRELIMINARY CONSTRUCTION DRAWINGS; THESE DRAWINGS SHALL NOT BE USED FOR CONSTRUCTION UNTIL APPROVED BY ALL AUTHORITIES HAVING JURISDICTION AND RELEASED BY THE ENGINEER OF RECORD.

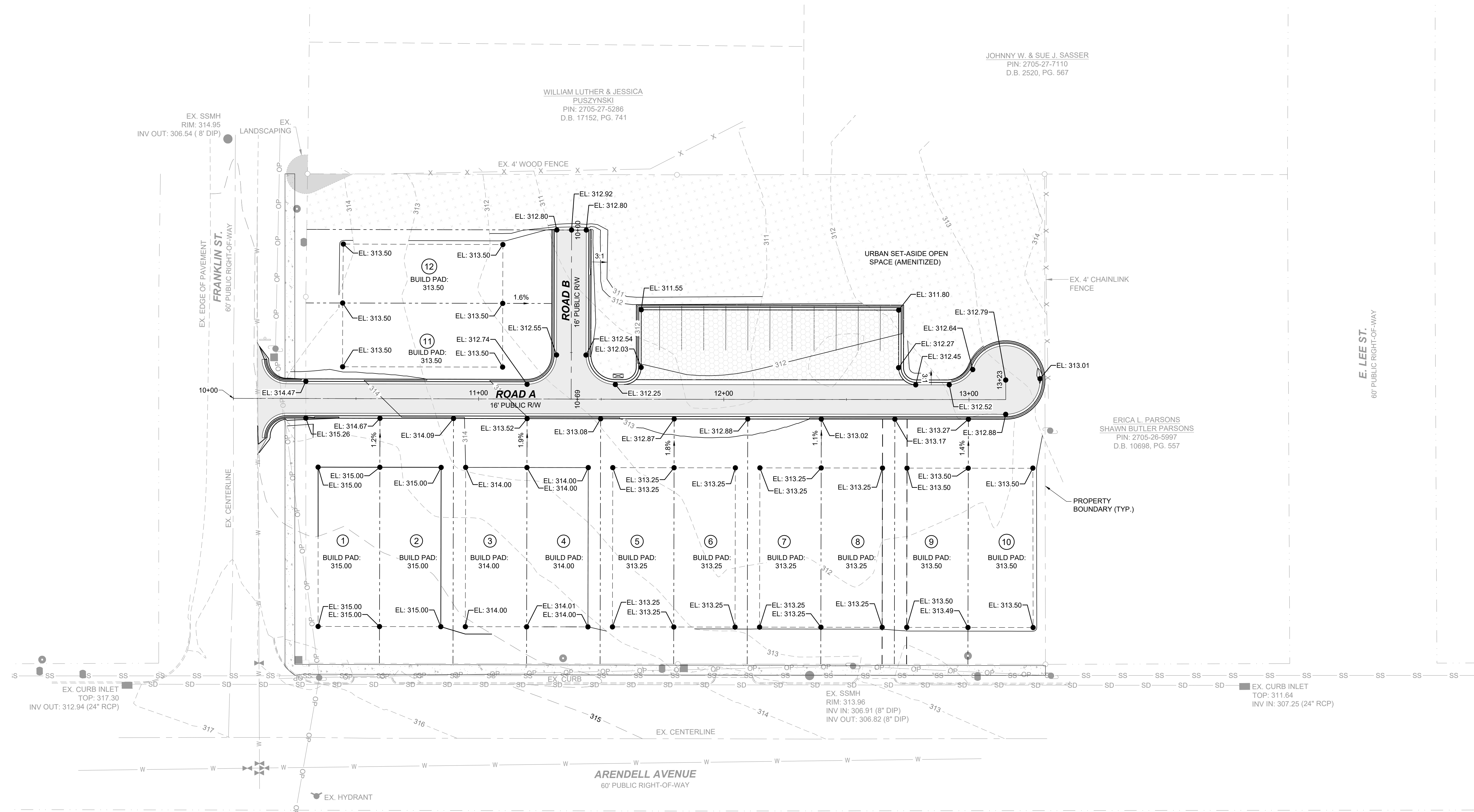

JOHNNY W. & SUE J. SASSER
 PIN: 2705-27-7110
 D.B. 2520, PG. 567

WILLIAM LUTHER & JESSICA
 PUSZYNSKI
 PIN: 2705-27-5286
 D.B. 17152, PG. 741

ERICA L. PARSONS
 SHAWN BUTLER PARSONS
 PIN: 2705-26-5997
 D.B. 10698, PG. 557

LEGEND:	
---	MASTER PLAN BOUNDARY
- - - -	ADJOINER PROPERTY LINE
W W	EXISTING WATERLINE
SS SS	EXISTING SANITARY SEWER
---	PROPOSED LOT LINE
=====	PROPOSED ROLL CURB AND GUTTER
---	EXISTING MAYOR CONTOUR
---	EXISTING MINOR CONTOUR
---	PROPOSED MAYOR CONTOUR
---	PROPOSED MINOR CONTOUR
○	EXISTING FIRE HYDRANT
○	EXISTING WATER VALVE
○	EXISTING UTILITY POLE
○	EXISTING TELEPHONE PEDEST

GRADING NOTES:

- ALL CONSTRUCTION SHALL BE IN ACCORDANCE WITH TOWN OF ZEBULON, CITY OF ZEBULON, NCDOT, AND/OR WAKE COUNTY STANDARDS AS APPLICABLE.
- CONTRACTOR SHALL COORDINATE ALL GRADING OPERATIONS WITH THE OWNERS GEOTECHNICAL ENGINEER.

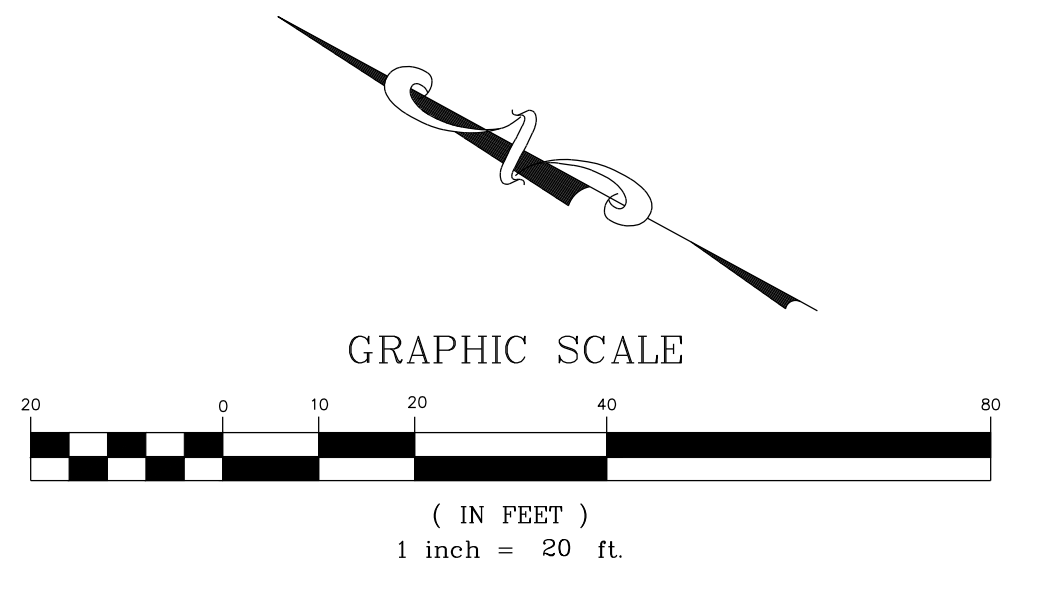

PRELIMINARY CONSTRUCTION DRAWINGS; THESE DRAWINGS SHALL NOT BE USED FOR CONSTRUCTION UNTIL APPROVED BY ALL AUTHORITIES HAVING JURISDICTION AND RELEASED BY THE ENGINEER OF RECORD.

NO.	REVISIONS	DATE	BY

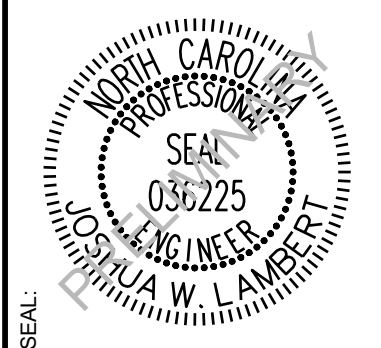

STRONGROCK
 ENGINEERING GROUP
 STRONG ROCK ENGINEERING GROUP, PLLC | COMPANY LICENSE # P-2166
 8362 SIX FORKS RD., SUITE 104 RALEIGH, NC 27615 | JOSH@STRONGROCKENGINEERING.COM

STRONG ROCK PROJECT	NOT FOR CONSTRUCTION	SCALE AS SHOWN	DESIGNED BY RLB	DRAWN BY SRG	CHECKED BY JWL
---------------------	----------------------	----------------	-----------------	--------------	----------------

TRUE- ZEBULON-ARENDELL
 TOWN OF ZEBULON, WAKE COUNTY, NORTH CAROLINA
 CONSTRUCTION PLANS
GRADING PLAN

DRAWING SHEET
C-4.0
 05 OF 09

JOHNNY W. & SUE J. SASSER
 PIN: 2705-27-7110
 D.B. 2520, PG. 567

WILLIAM LUTHER & JESSICA
 PUSZYNSKI
 PIN: 2705-27-5286
 D.B. 17152, PG. 741

DRAINAGE NOTES:

- CONTRACTOR SHALL MAINTAIN POSITIVE SLOPE AND OUTFALL OF ANY FOUNDATION DRAIN SYSTEMS.
- ALL STORM DRAIN HOODS, MANHOLE COVERS AND GRATES ARE TO BE LABELED "NO DUMPING DRAINS TO STREAM".

LEGEND:

- EXISTING PROPERTY LINE
- ROADWAY CENTER LINE
- PROPOSED PROPERTY LINE
- STANDARD ROLL CURB & GUTTER
- PROPOSED STORM DRAIN LINE
- PROPOSED STORM DRAIN LINE

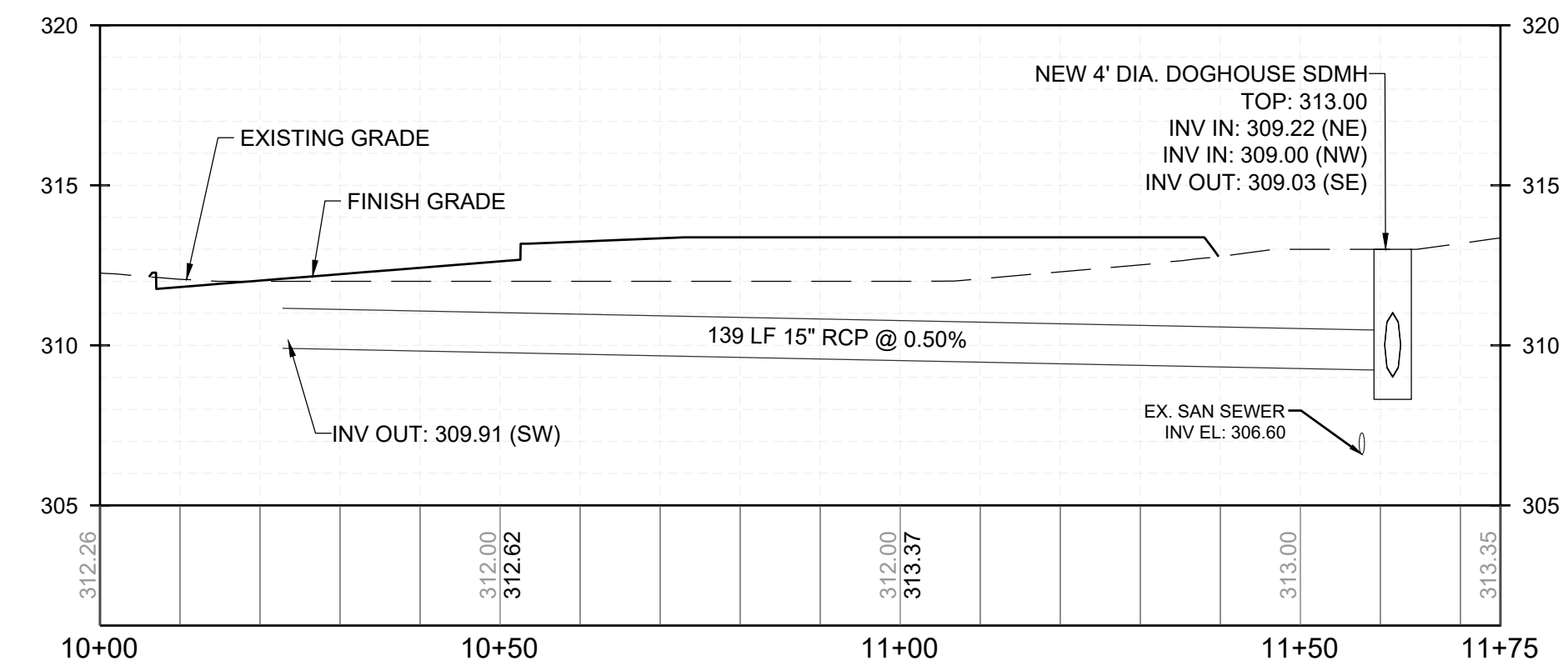
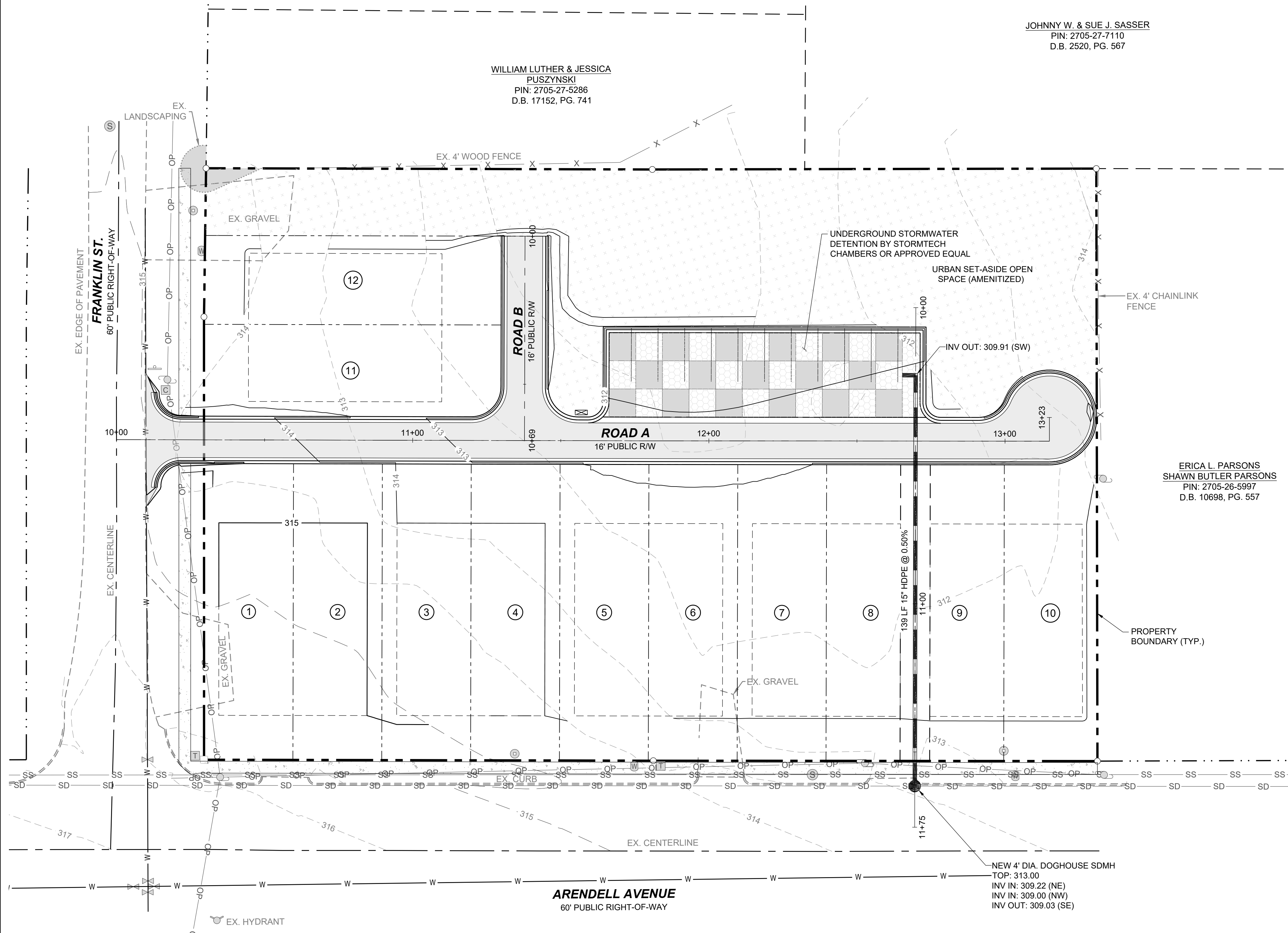

PROPOSED STORM DRAINAGE - PROFILE

VERTICAL: 1" = 5'
 HORIZONTAL: 1" = 20'

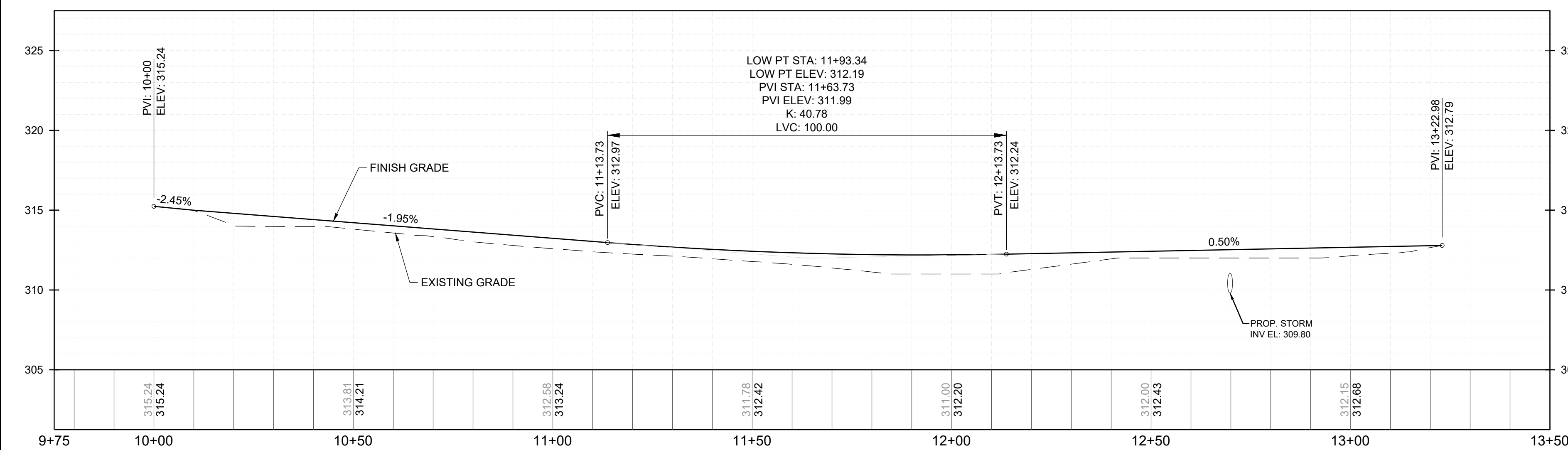

PROPOSED ROAD A - PROFILE

VERTICAL: 1" = 5'
 HORIZONTAL: 1" = 20'

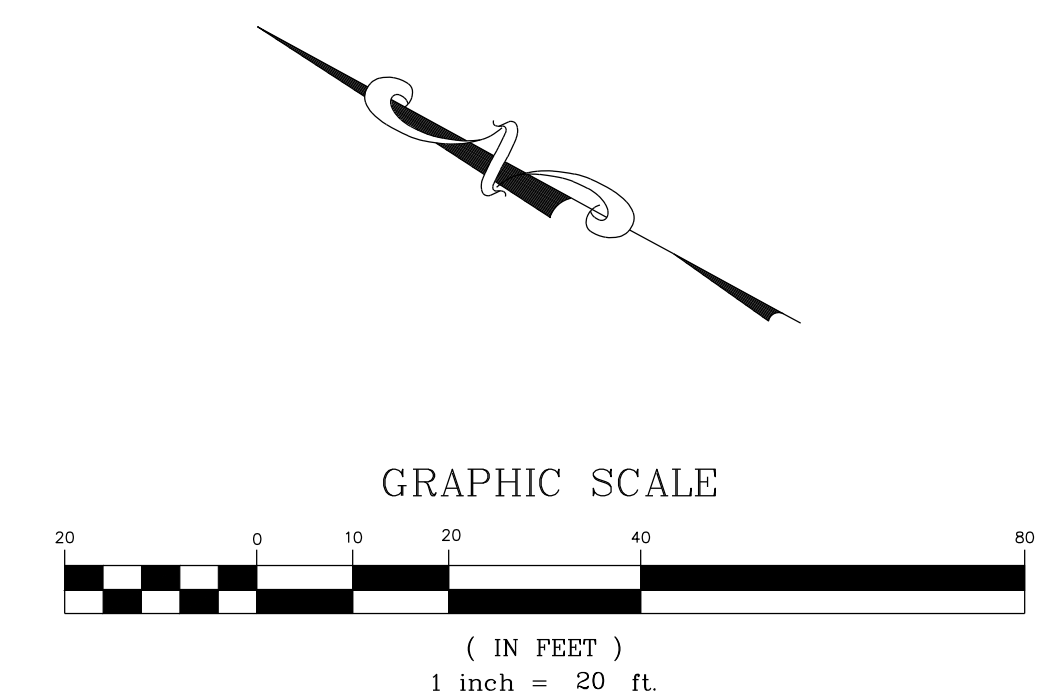

PRELIMINARY CONSTRUCTION DRAWINGS; THESE DRAWINGS SHALL NOT BE USED FOR CONSTRUCTION UNTIL APPROVED BY ALL AUTHORITIES HAVING JURISDICTION AND RELEASED BY THE ENGINEER OF RECORD.

NO.	REVISIONS	DATE	BY

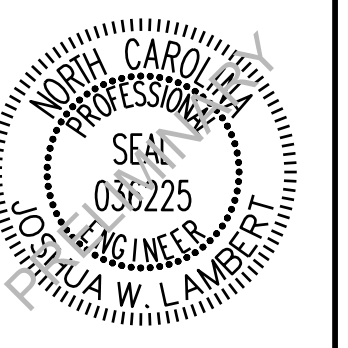

STRONGROCK
 ENGINEERING GROUP
 STRONG ROCK ENGINEERING GROUP, PLLC | COMPANY LICENSE # P-2166
 8362 SIX FORKS RD., SUITE 104 RALEIGH, NC 27615 | JOSH@STRONGROCKENGINEERING.COM

STRONG ROCK PROJECT	NOT FOR CONSTRUCTION	SCALE AS SHOWN	DESIGNED BY	RLB	SRG	JWL

TRUE- ZEBULON-ARENDELL
 TOWN OF ZEBULON, WAKE COUNTY, NORTH CAROLINA
 CONSTRUCTION PLANS
STORMWATER PLAN

DRAWING SHEET
C-5.0

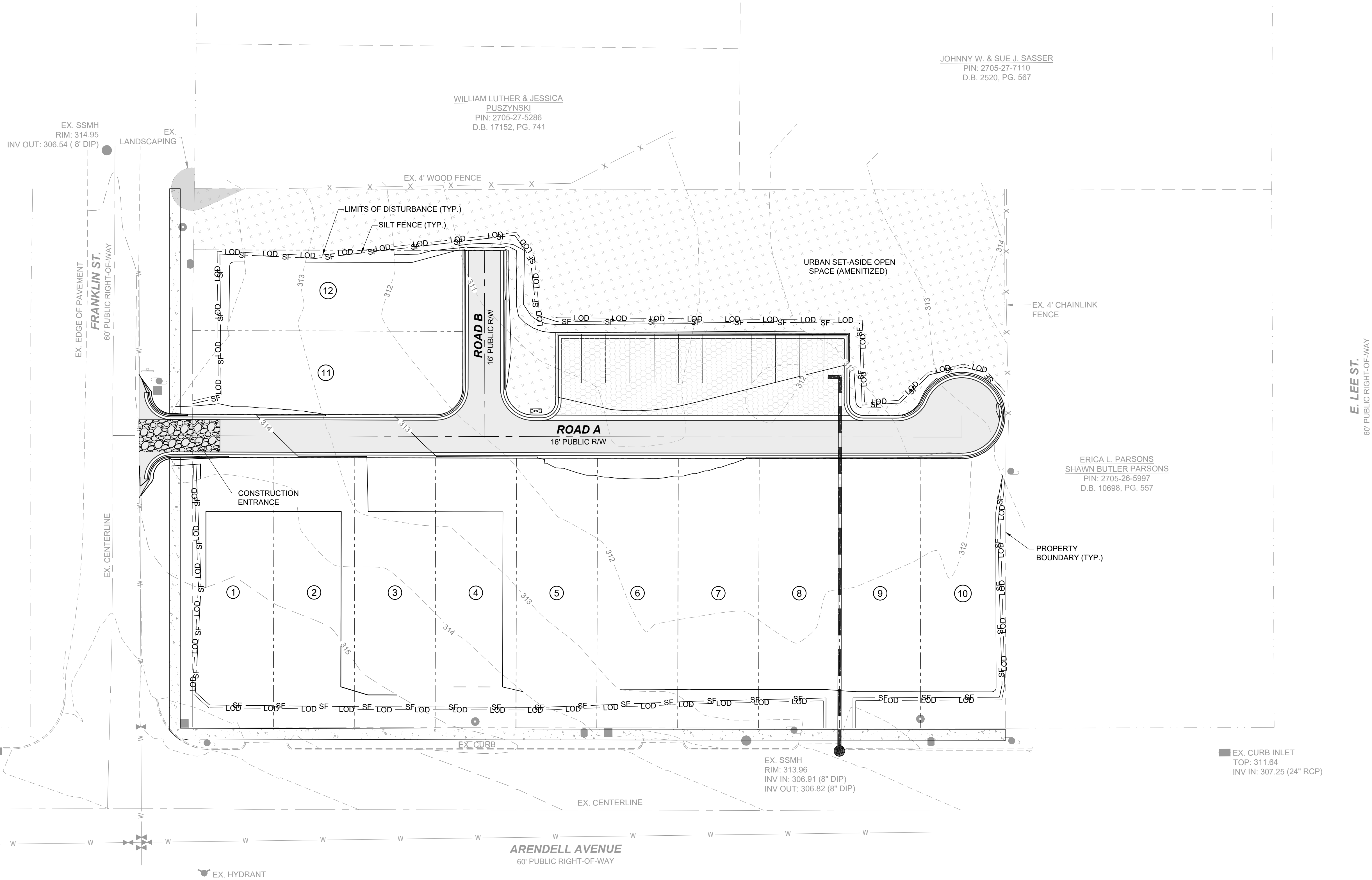

LEGEND:

	EXISTING PROPERTY LINE
	LIMITS OF DISTURBANCE
	SILT FENCE
	CONSTRUCTION ENTRANCE

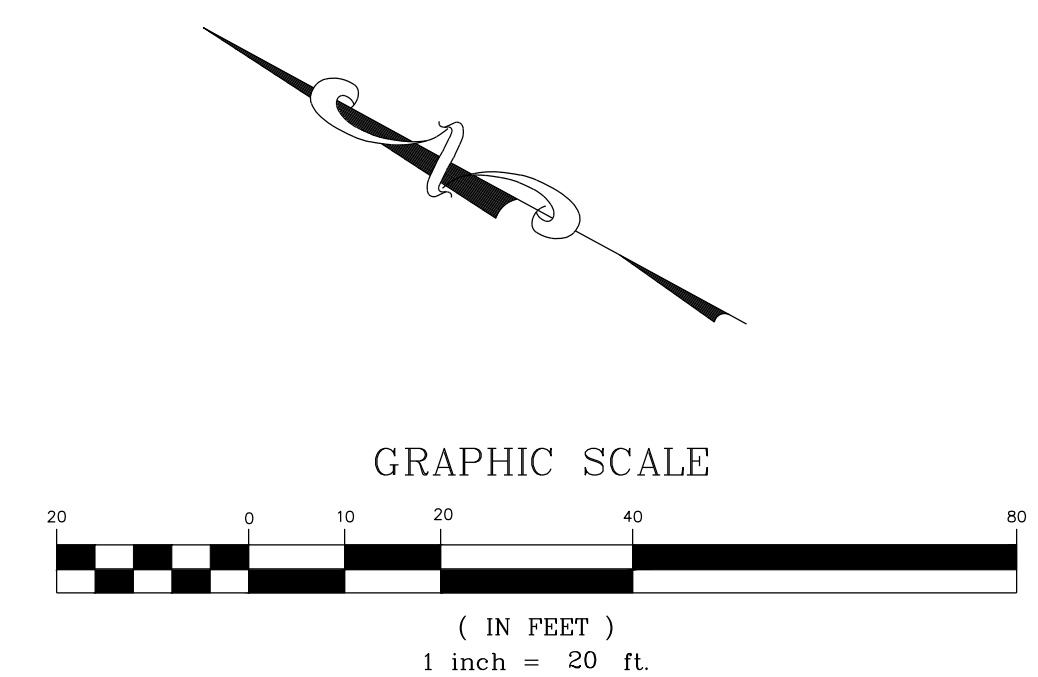

PRELIMINARY CONSTRUCTION DRAWINGS; THESE DRAWINGS SHALL NOT BE USED FOR CONSTRUCTION UNTIL APPROVED BY ALL AUTHORITIES HAVING JURISDICTION AND RELEASED BY THE ENGINEER OF RECORD.

JOHNNY W. & SUE J. SASSER
PIN: 2705-27-7110
D.B. 2520, PG. 567

WILLIAM LUTHER & JESSICA
PUSZYNSKI
PIN: 2705-27-5286
D.B. 17152, PG. 741

ERICA L. PARSONS
SHAWN BUTLER PARSONS
PIN: 2705-26-5997
D.B. 10698, PG. 557

NO.	REVISIONS	DATE	BY

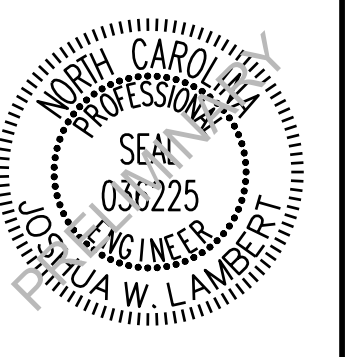

STRONGROCK
ENGINEERING GROUP
STRONG ROCK ENGINEERING GROUP, PLLC | COMPANY LICENSE # P-2166
8362 SIX FORKS RD., SUITE 104 RALEIGH, NC 27615 | JOSH@STRONGROCKENGINEERING.COM

STRONG ROCK PROJECT	NOT FOR CONSTRUCTION	SCALE AS SHOWN	DESIGNED BY RLB	DRAWN BY SRG	CHECKED BY JWL
---------------------	----------------------	----------------	-----------------	--------------	----------------

TRUE- ZEBULON-ARENDELL
TOWN OF ZEBULON, WAKE COUNTY, NORTH CAROLINA
CONSTRUCTION PLANS
EROSION CONTROL PLAN

JOHNNY W. & SUE J. SASSER
 PIN: 2705-27-7110
 D.B. 2520, PG. 567

WILLIAM LUTHER & JESSICA
 PUSZYNSKI
 PIN: 2705-27-5286
 D.B. 17152, PG. 741

ERICA L. PARSONS
 SHAWN BUTLER PARSONS
 PIN: 2705-26-5997
 D.B. 10698, PG. 557

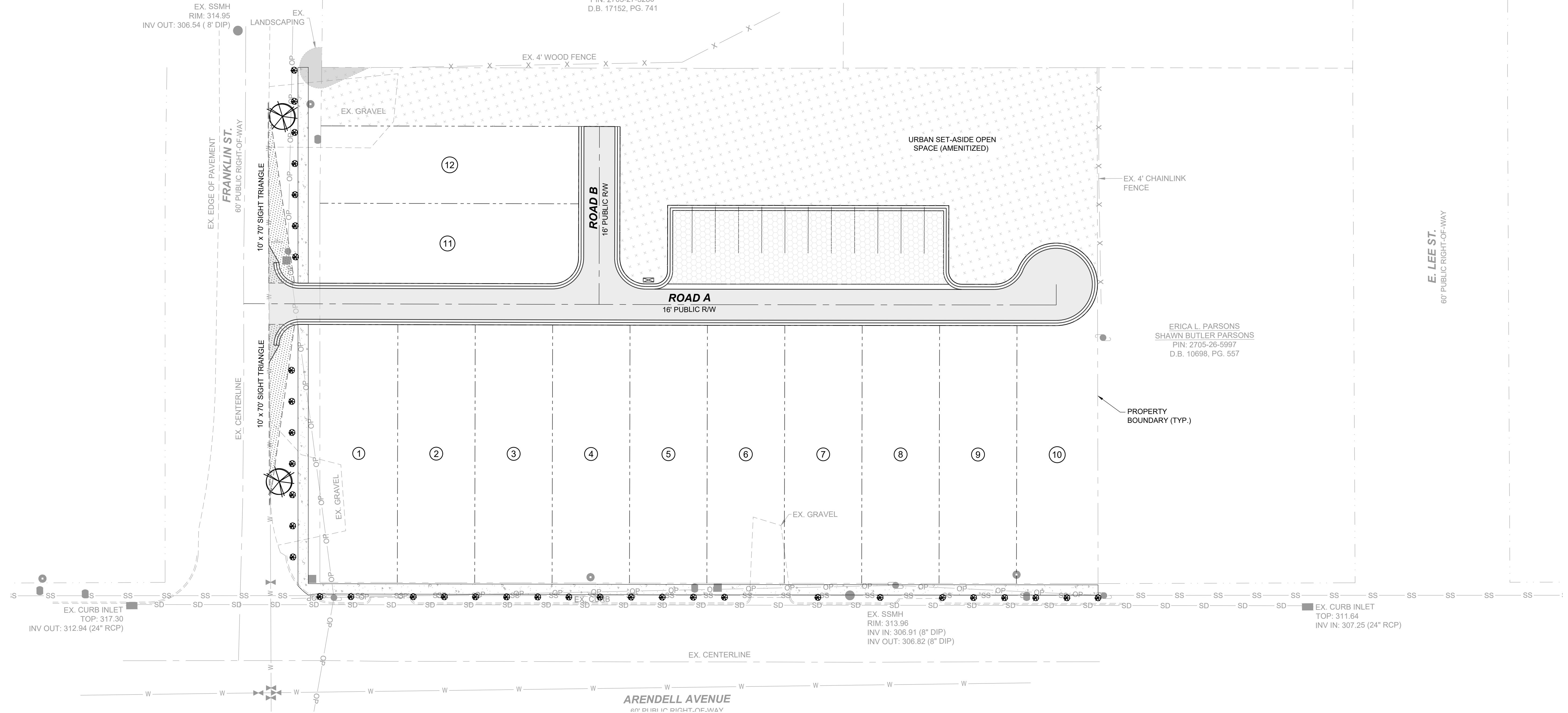

GENERAL PLANTING NOTES:

- STREET TREES SHALL BE INSTALLED SUCH THAT ONE TREE IS REQUIRED ALONG THE RESIDENTIAL STREET AS SHOWN, SPACED EVERY 40 FEET.
- DO NOT PLACE STREET TREES WITHIN A PUBLIC STORM OR UTILITY EASEMENT.
- ALL CANOPY TREES SHALL BE MIN. 8' TALL AND 2" CALIPER AT TIME OF PLANTING.
- ALL UNDERSTORY TREES SHALL BE MIN. 6' TALL AND 1" CALIPER AT TIME OF PLANTING.
- LANDSCAPING IN AREAS OUTSIDE OF RIGHT OF WAY ARE TO BE PROVIDED BY THE DEVELOPER. ANY LANDSCAPING INSTALLED WITHIN THESE AREAS ARE TO BE MAINTAINED BY THE DEVELOPER UNTIL HOME OWNERS ASSOCIATION (HOA) IS ESTABLISHED. HOA WILL BE RESPONSIBLE FOR CONTINUED MAINTENANCE OF LANDSCAPING AND ANY IMPROVEMENTS OUTSIDE THE RIGHT OF WAY.
- ADDITIONAL LANDSCAPING ON SITE MAYBE PROVIDED BY DEVELOPER.

LEGEND:

- CAMELLIA (CJ)
- TRIDENT MAPLE (AB)

PLANTING SCHEDULE:

KEY	QTY	BOTANICAL NAME	COMMON NAME	CONTAINER	SIZE	HEIGHT
PERIMETER BUFFERS						
AB	2	ACER BUERGERIANUM	TRIDENT MAPLE	B&B	1" CAL	6'
CJ	35	CAMELLIA JAPONICA	CAMELLIA	GAL.	3 GAL	18"

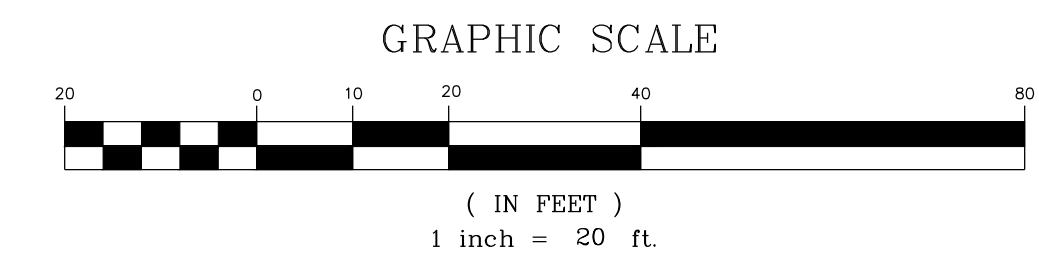
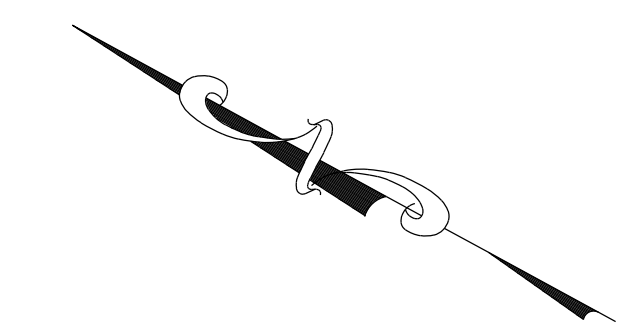

PRELIMINARY CONSTRUCTION DRAWINGS; THESE DRAWINGS SHALL NOT BE USED FOR CONSTRUCTION UNTIL APPROVED BY ALL AUTHORITIES HAVING JURISDICTION AND RELEASED BY THE ENGINEER OF RECORD.

NO.	REVISIONS	DATE	BY

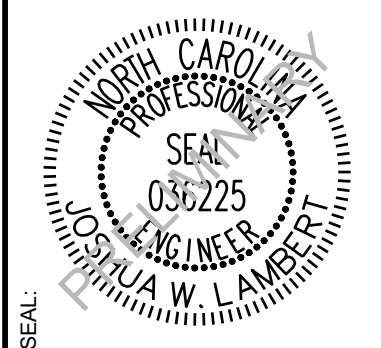

STRONGROCK
 ENGINEERING GROUP
 STRONG ROCK ENGINEERING GROUP, PLLC | COMPANY LICENSE # P-2166
 8362 SIX FORKS RD., SUITE 104 RALEIGH, NC 27615 | JOSH@STRONGROCKENGINEERING.COM

STRONG ROCK PROJECT	NOT FOR CONSTRUCTION	SCALE AS SHOWN	DESIGNED BY RLB	DRAWN BY SRG	CHECKED BY JWL
---------------------	----------------------	----------------	-----------------	--------------	----------------

TRUE- ZEBULON-ARENDELL
 TOWN OF ZEBULON, WAKE COUNTY, NORTH CAROLINA
 CONSTRUCTION PLANS
LANDSCAPING PLAN

DRAWING SHEET
C-7.0

08 OF 09

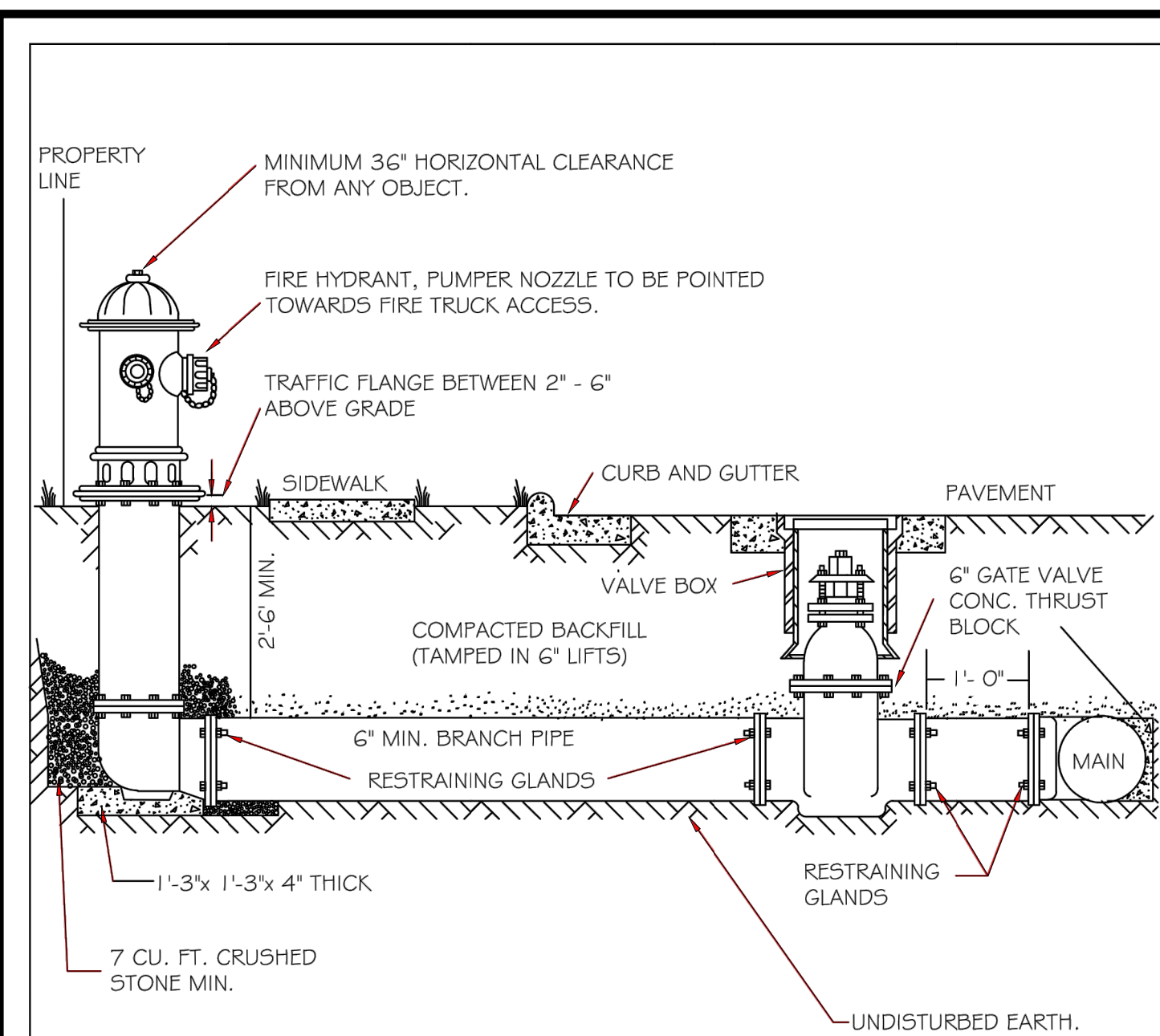

- NOTES:
1. FIRE HYDRANT SHALL BE AS MANUFACTURED: MUELLER, AMERICAN DARLING, KENNEDY, M&H, WATEROUS, CLOW, EAST JORDAN IRON WORKS, OR US PIPE.
 2. BRANCH PIPE SHALL BE DUCTILE IRON AWWA C150-96
 3. 6" GATE VALVE SHALL BE AWWA C500-96 OPEN LEFT
 4. STEEL RODS AND BOLTS SHALL BE #2 HOT DIPPED GALVANIZED
 5. FIRE HYDRANTS WILL BE INSTALLED IN TRUE VERTICAL POSITION
RODS SHALL NOT BE COUPLED MORE THAN ONCE. IF THE LENGTH FROM THE VALVE TO THE HYDRANT EXCEEDS 20' THEN A MECHANICAL RESTRAINING GLAND WITH A REBAR CAGE SHALL BE INSTALLED NO MORE THAN 10' FROM HYDRANT AND POURED IN CONCRETE.
FIRE HYDRANTS TO BE LOCATED IN ROW OR 2 FOOT EASEMENT ADJACENT TO ROW

ANYTIME SITE WORK, CONSTRUCTION, ROAD WORK, OR ANY OTHER WORK CHANGES THE GRADE OF THE FIRE HYDRANT, THE PERSON RESPONSIBLE FOR ADJUSTING THE FIRE HYDRANT TO STAY WITHIN COMPLIANCE.

CITY OF RALEIGH				
DEPARTMENT OF PUBLIC UTILITIES				
STANDARD FIRE HYDRANT INSTALLATION DETAIL				
DWG. NO.	REVISIONS	DATE	REVISIONS	DATE
W-4	ABB	4-6-04	FAP	2/17/09
	DHL	2/14/08		

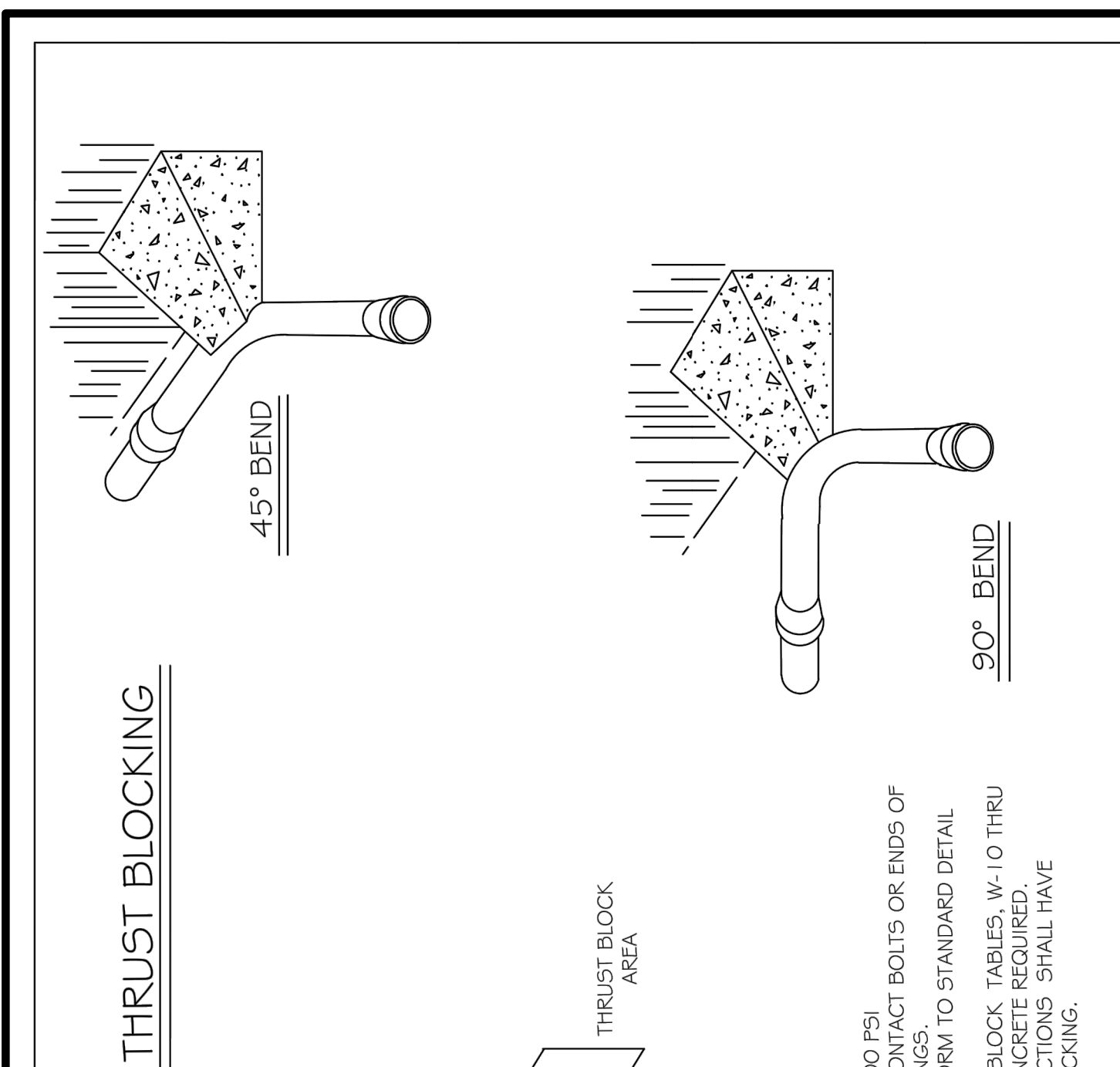

- NOTES:
1. CONCRETE SHALL BE 3000 PSI
 2. MECHANICAL JOINT BOLTS OR ENDS OF MECHANICAL JOINT FITTINGS
 3. TRENCHES SHALL CONFORM TO STANDARD DETAIL W-3.
 4. SEE STANDARD THRUST BLOCK TABLES, W-10 THRU W-11, FOR AREA OF CONCRETE REQUIRED.
 5. ALL BENDS AND INTERSECTIONS SHALL HAVE CONCRETE THRUST BLOCKING.

CITY OF RALEIGH				
DEPARTMENT OF PUBLIC UTILITIES				
STANDARD THRUST BLOCKING VIEWS				
DWG. NO.	REVISIONS	DATE	REVISIONS	DATE
W-9	D.W.C.	3-1-87	RRH	3-31-00
		9-7-99	D.H.L.	6-18-08

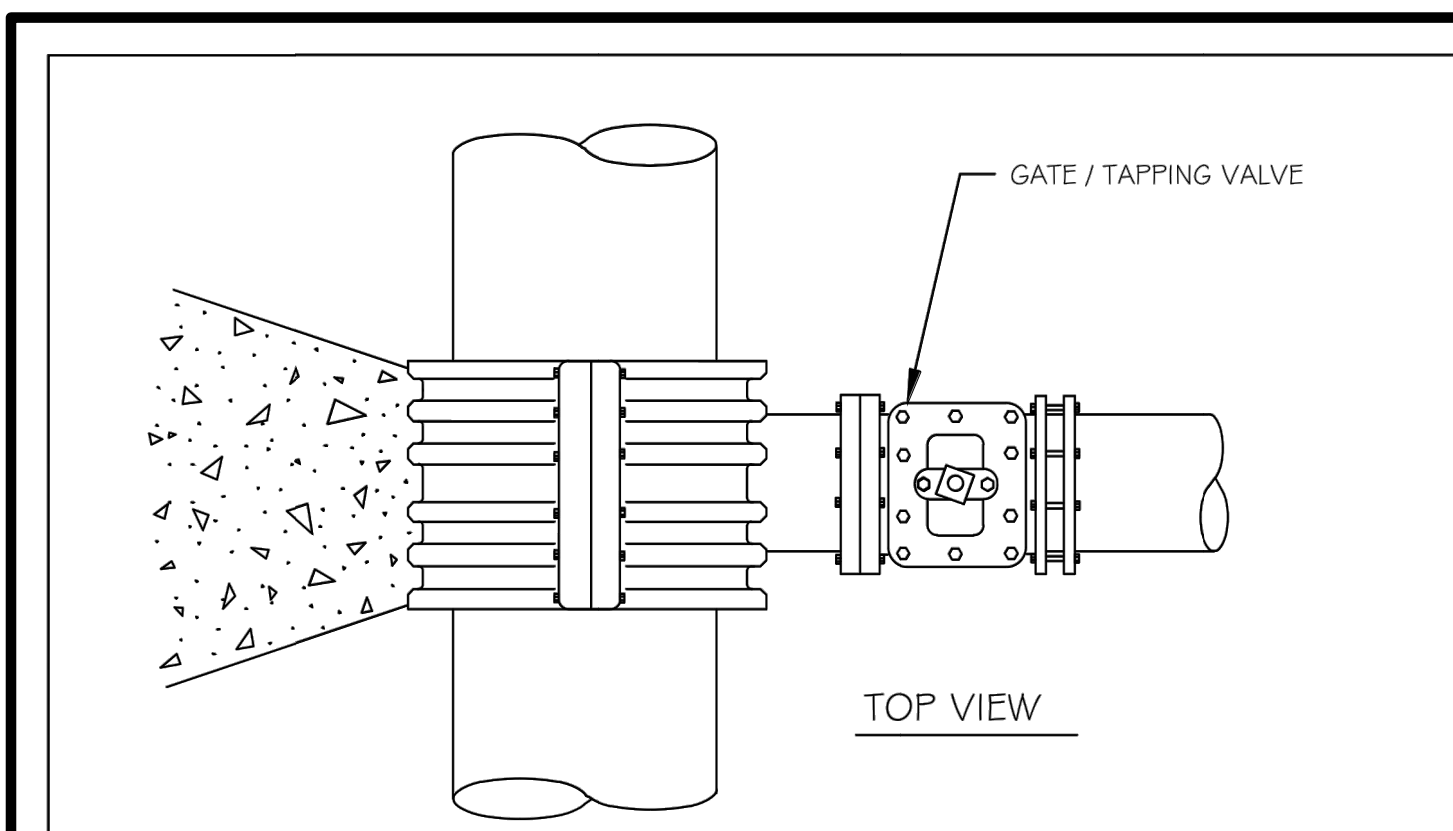

3000 PSI SOLID CONCRETE SHALL BE USED AS FOOTING FOR DUCTILE IRON PIPE.

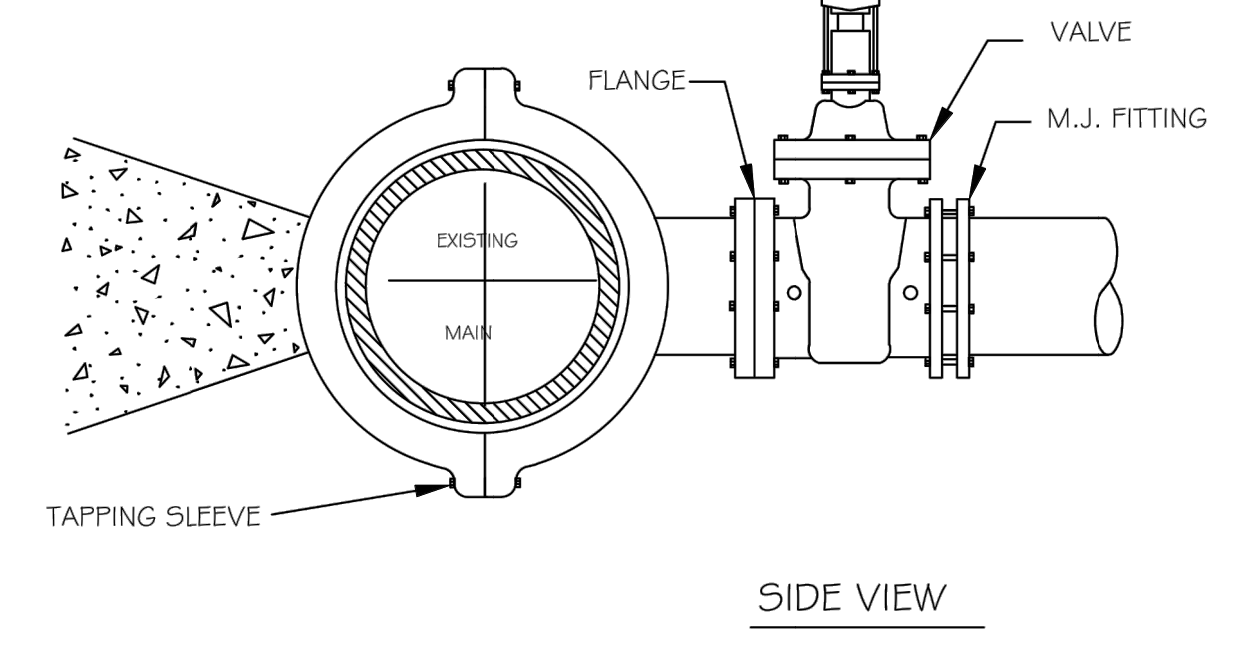

- NOTES:
1. CONCRETE SHALL NOT CONTACT BOLTS OR ENDS OF MECHANICAL JOINT FITTINGS.
 2. SEE STANDARD REACTION BLOCK TABLES, W-10 AND W-11 FOR AREA OF CONCRETE REQUIRED.

CITY OF RALEIGH				
DEPARTMENT OF PUBLIC UTILITIES				
4" - 24" STANDARD TAPPING SLEEVE AND VALVE ASSEMBLY				
DWG. NO.	REVISIONS	DATE	REVISIONS	DATE
W-14	Y.C.A.	2-31-91	RRH	3-31-00
	D.W.C.	9-7-99	J.P.S.	11-1-10

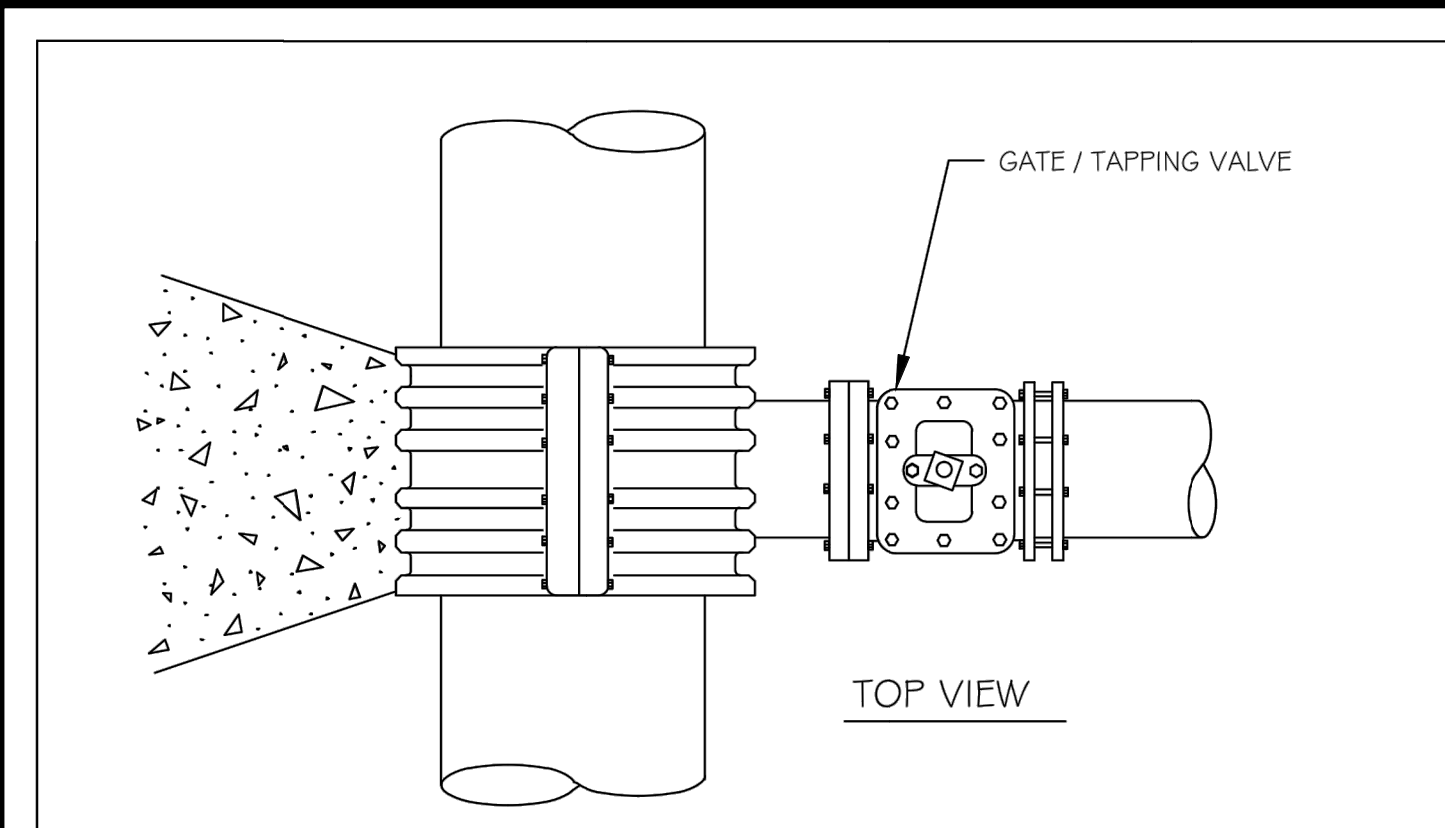

3000 PSI SOLID CONCRETE SHALL BE USED AS FOOTING FOR DUCTILE IRON PIPE.

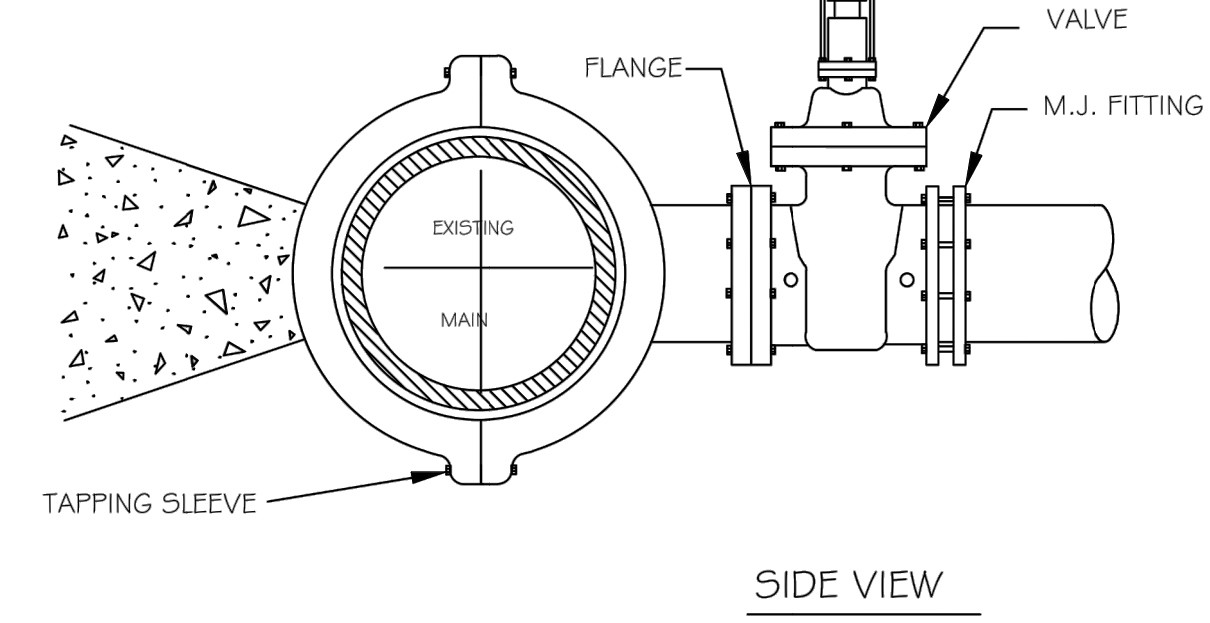

- NOTES:
1. CONCRETE SHALL NOT CONTACT BOLTS OR ENDS OF MECHANICAL JOINT FITTINGS.
 2. SEE STANDARD REACTION BLOCK TABLES, W-10 AND W-11 FOR AREA OF CONCRETE REQUIRED.

CITY OF RALEIGH				
DEPARTMENT OF PUBLIC UTILITIES				
4" - 24" STANDARD TAPPING SLEEVE AND VALVE ASSEMBLY				
DWG. NO.	REVISIONS	DATE	REVISIONS	DATE
W-14	Y.C.A.	12-31-91	RRH	3-31-00
	D.W.C.	9-7-99	J.P.S.	11-1-10

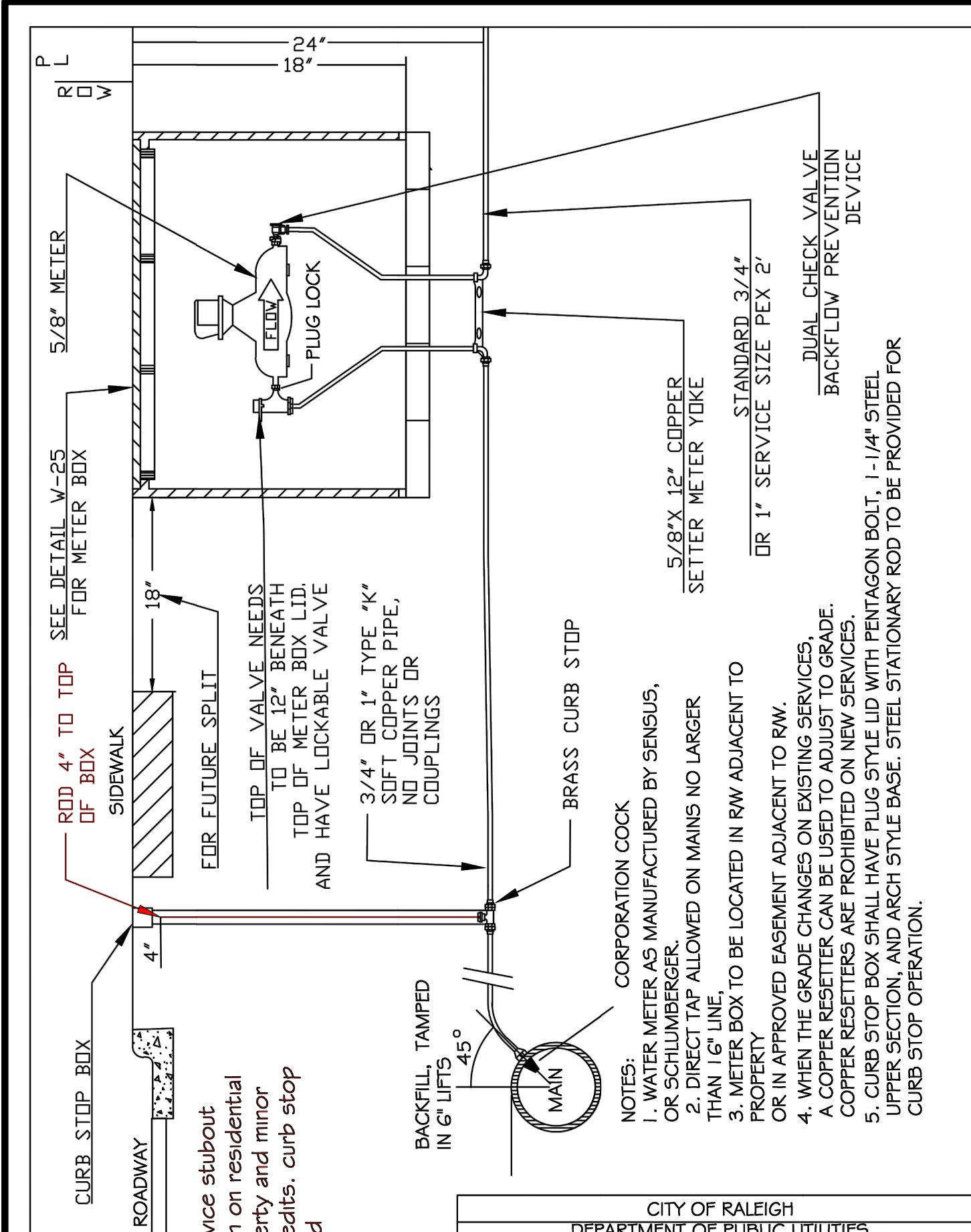

- NOTES:
1. WATER METER AS MANUFACTURED BY SENSUS, OR SCHLIMBERGER.
 2. DIRECT TAP ALLOWED ON MAINS NO LARGER THAN 16" LINE.
 3. METER BOX TO BE LOCATED IN ROW ADJACENT TO PROPERTY OR IN APPROVED EASEMENT ADJACENT TO RW.
 4. WHEN THE GRADE CHANGES ON EXISTING SERVICES, COOPER RESTRICTIONS ARE PROHIBITED ON NEW SERVICES.
 5. CURB STOP BOX SHALL HAVE PLUG STYLE LID WITH PRANTAGON BOLT, 1-1/4" STEEL UPPER SECTION, AND ARCH STYLE BASE. STEEL STATIONARY ROD TO BE PROVIDED FOR CURB STOP OPERATION.

CITY OF RALEIGH				
DEPARTMENT OF PUBLIC UTILITIES				
STANDARD 3/4" & 1" WATER SERVICE INSTALLATION				
DWG. NO.	REVISIONS	DATE	REVISIONS	DATE
W-23	ABB	4-6-04	RKV	7/23/13
	D.H.L.	6/18/08		

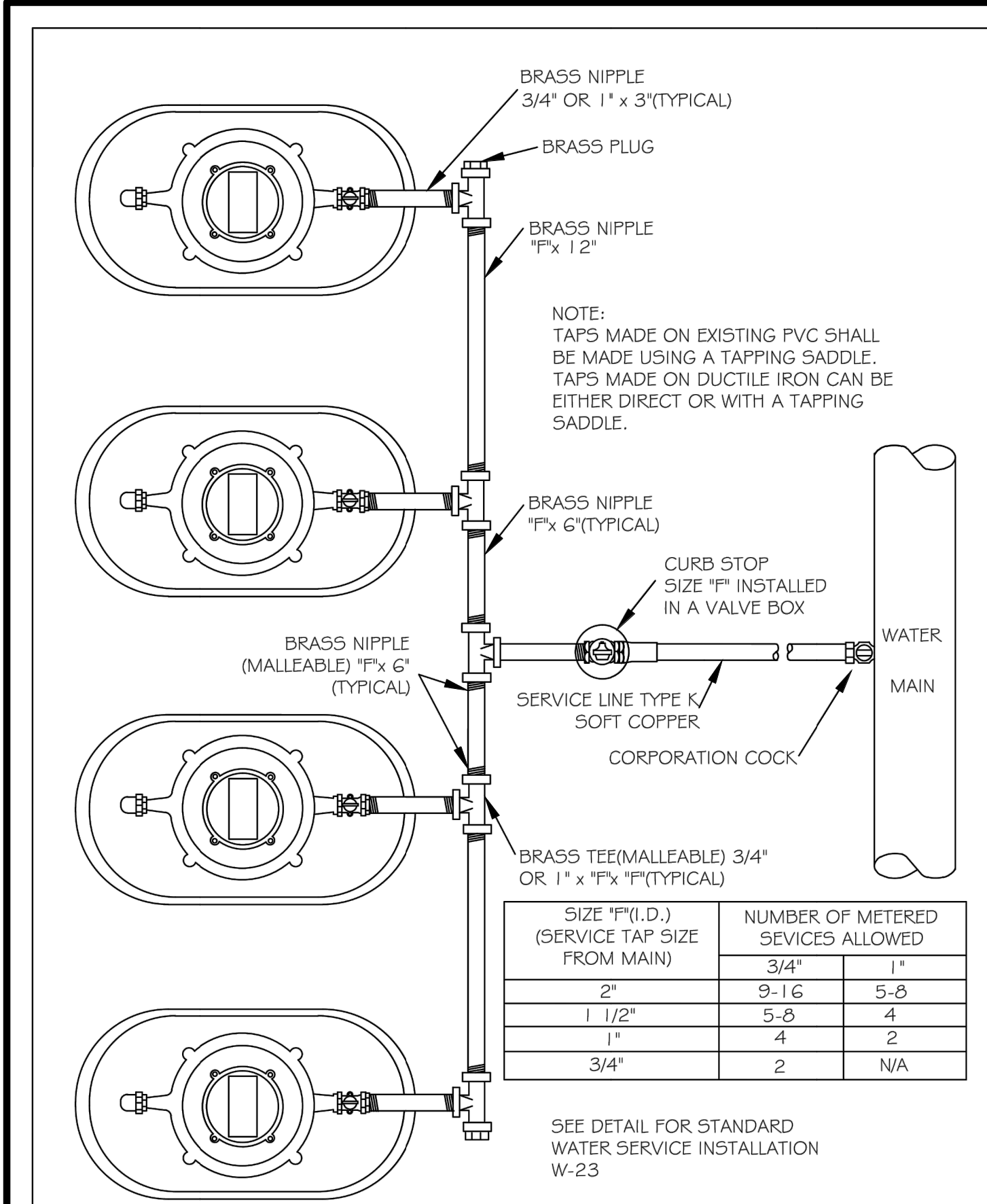

CITY OF RALEIGH				
DEPARTMENT OF PUBLIC UTILITIES				
STANDARD GANG METER ASSEMBLY				
DWG. NO.	REVISIONS	DATE	REVISIONS	DATE
W-26	METERED SERV.	4-1-82	D.W.C.	11-18-99
	Y.C.A.	12-31-91	J.P.S.	11-4-10

CITY OF ZEBULON - PLANS AUTHORIZED FOR CONSTRUCTION:

ELECTRONIC APPROVAL: THIS APPROVAL IS BEING ISSUED ELECTRONICALLY. THIS APPROVAL IS VALID ONLY UPON THE SIGNATURE OF A CITY OF ZEBULON REVIEW OFFICER BELOW. THE CITY WILL RETAIN A COPY OF THE APPROVED PLANS. ANY WORK AUTHORIZED BY THIS APPROVAL MUST PROCEED IN ACCORDANCE WITH THE PLANS KEPT ON FILE WITH THE CITY. THIS ELECTRONIC APPROVAL MAY NOT BE EDITED ONCE ISSUED. ANY MODIFICATION TO THIS APPROVAL ONCE ISSUED WILL INVALIDATE THIS APPROVAL.

CITY OF ZEBULON DEVELOPMENT APPROVAL _____

ZEBULON WATER REVIEW OFFICER

PRELIMINARY CONSTRUCTION DRAWINGS: THESE DRAWINGS SHALL NOT BE USED FOR CONSTRUCTION UNTIL APPROVED BY ALL AUTHORITIES HAVING JURISDICTION AND RELEASED BY THE ENGINEER OF RECORD.

STRONG ROCK PROJECT	NOT FOR CONSTRUCTION	SCALE AS SHOWN	DESIGNED BY RLB	DRAWN BY SRG	CHECKED BY JWL
<h1>STRONG ROCK</h1> <p>ENGINEERING GROUP</p> <p>STRONG ROCK ENGINEERING GROUP, PLLC COMPANY LICENSE # P-2166 8362 SIX FORKS RD., SUITE 104 RALEIGH, NC 27615 JOSH@STRONGROCKENGINEERING.COM</p>					
<p>TRUE- ZEBULON-ARENDELL TOWN OF ZEBULON, WAKE COUNTY, NORTH CAROLINA CONSTRUCTION PLANS WATER DETAILS</p>					
<p>DRAWING SHEET</p> <p>D-1.0</p> <p>09 OF 09</p>					